



Torque hinges/ detent hinges



Art.:6871



Art.:6875



Art.:6871.04



Art.:6871.05



Art.:6876



Art.: 150.SK-T-ZA



Art.: 150.SK-T-ZA

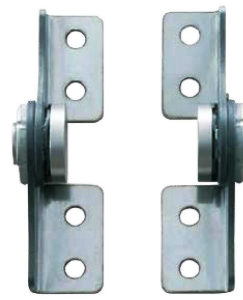

Art.: 150.HG-TA



Art.: 150.HG-IT MC



Art.: 150.SF-TH



Art.: 150.HG-TS

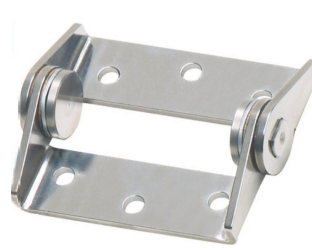

Art.: 150.HG-ITS



Art.: 150.HG-ITM

Torque hinges

The advantage of torque hinges is that every possible desirable positioning may be kept.
The torque is adjusted through an adjustment screw.

Art. no.: **6871** (drilled and countersunk)

Set screw: hexagon socket 2.5
Temperature resistance: -20 °C up to + 80 °C

Max. tensile strength: 2240 N
Max. shear strength: 1050 N

Also available as:

Spring hinge see chapter „Spring hinges “

Detent hinge see chapter „Torque and detent hinges “

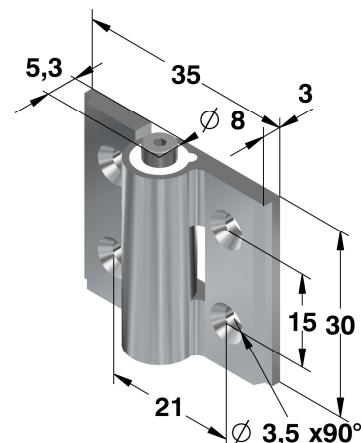

		Article no.		
Series	Execution	Material		
		Raw	Colourless	Black
		Alu. 6060 T5	Alu. 6060 T5	Alu. 6060 T5
6871	.01	.70	-	.77
6871	.02	-	.70	-

Art. no.: **6871** (drilled and countersunk)

Holding torque: 0 - 5 Nm max.
Set screw: hexagon socket 4
Temperature resistance: -20 °C up to + 80 °C

Max. tensile strength: 6000 N
Max. shear strength: 5000 N

Also available as:

Free running hinge see chapter “Hinges“

Spring hinge see chapter „Spring hinges “

Detent hinge see chapter „Torque and detent hinges “

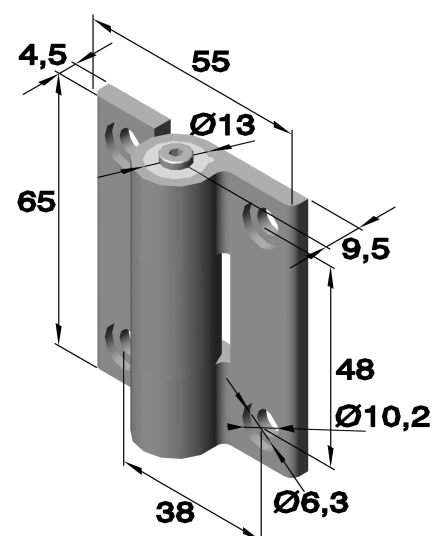

		Article no.	
Series	Execution	Material	
		Colourless	Black
		Alu. 6060 T5	Alu. 6060 T5
6871	.04	.70	.77

Torque hinges

Art. no.: **6871** (drilled and countersunk)

Holding torque: 0 - 5 Nm max.
Set screw: Hexagon socket 4
Temperature resistance: -20 °C up to + 80 °C

Max. tensile strength: 6000 N
Max. shear strength: 5000 N

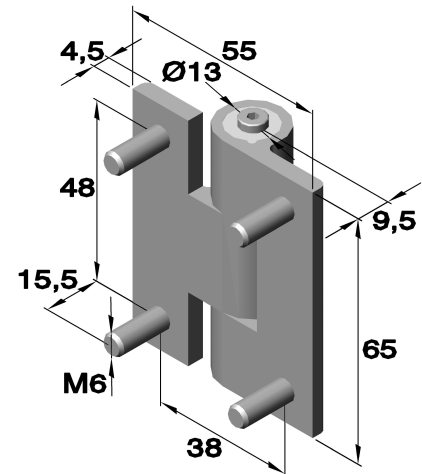

Article no.		Material	
Series	Execution	Raw	Black
		Alu. 6060 T5	Alu. 6060 T5
6871	.05	.70	.77

Art. no. **6876** (drilled and countersunk)⁹

Soft-closing hinge
Opens and closes steamed.
Feature till 115° guaranteed
Torque per Pair: 2,5 to 4,5 N.m

Also available as:

Free running hinge see chapter "Hinges"
Spring hinge see chapter "Spring hinges"

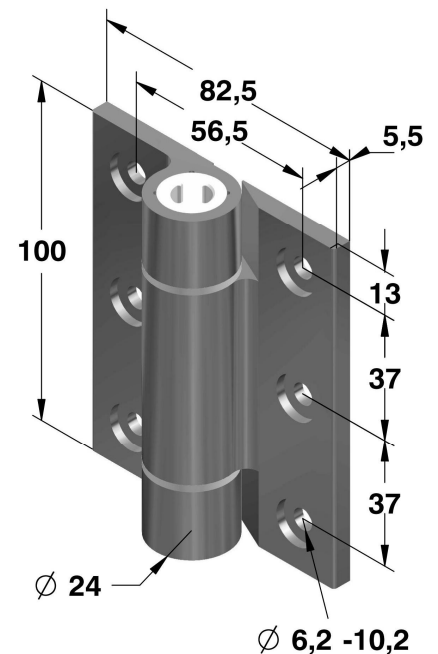

Article no.		Material	
Series	Execution	Anodized colourless	
		Aluminium 6060 T5	
6876	.06	.71	

Torque hinges

Art. no. 6877 (drilled)

Soft-Closing hinge
Opens and closes steamed

Feature till 115° guaranteed
Torque per Pair: 2,2 bis 3,0 N.m

Operating temperature: 0 °C- 40 °C

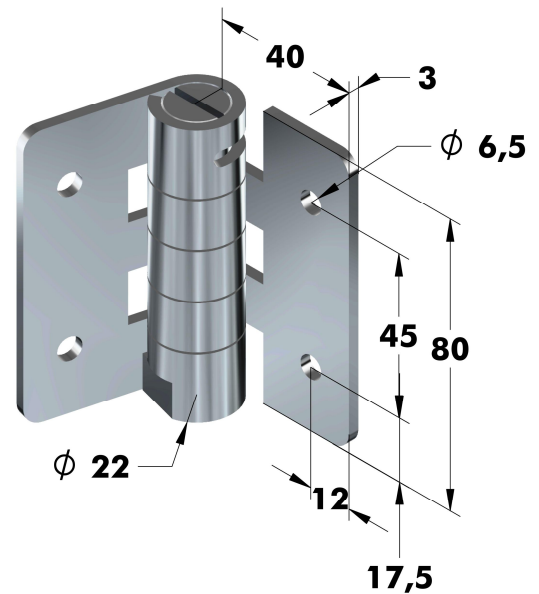

Article no.		
Series	Execution	Material
		Raw
6877	.01	Stainless steel
		.30

Art. no.: 150.SK-T-ZA (drilled and countersunk)
with constant torque.

Cover made of chrome plated plastic.

The declared torque could boast tolerances.

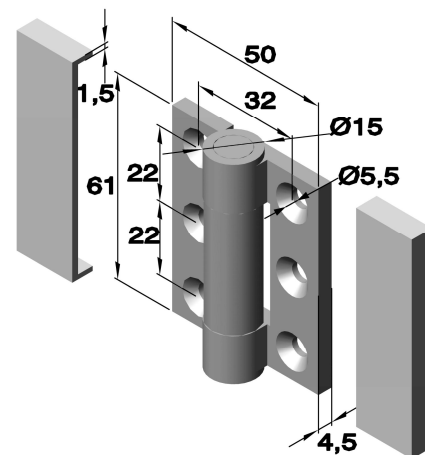

Article no.			Torque in N.m
Series	Execution	Material	
		150.SK-T-ZA	1CR
		Zamak	
150.SK-T-ZA	2CR	.03	1,9
150.SK-T-ZA	3CR	.03	1,5

Art. no.: 150.HG-TS

with constant torque.

Operating temperature: -10 °C ~ 50 °C
Operating humidity: ~ 90% RH (oder weniger)

The declared torque could boast tolerances.

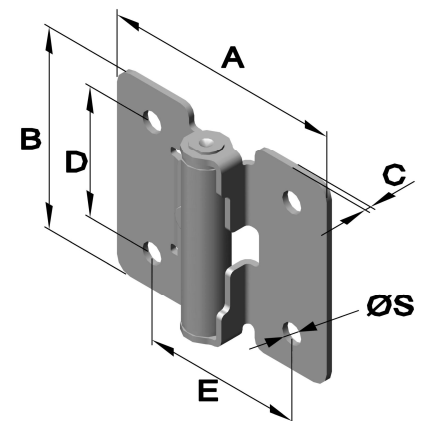

Article no.			Dimension in mm						Torque
Series	Execution	Material	A	B	C	D	E	ØS	in N.m.
		Raw							
150.HG-TS	03	Stainless steel	36	32	1,2	18	21	4,3	0,35
	07	.30	48	40	1,2	26	32	4,3	0,7
	15	.30	48	50	2	36	32	4,3	1,5

Torque hinges

Art.no.: 150.SFTH (drilled)

with constant torque.

Operating temperature: -20°C ~ 60°C

The declared torque could boast tolerances.

Article no.			Torque in N.m.
Series	Execution	Material	
		Raw Stainless steel	
150.SFTH	-02-5	.30	0,5

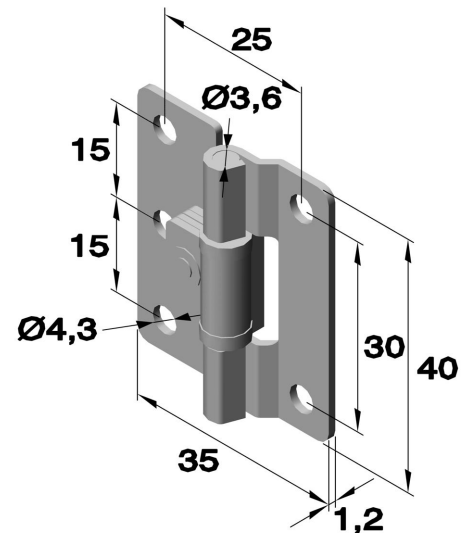

Art.no.: 150.SFTH (drilled)

with constant torque.

Operating temperature: -20°C ~ 60°C

The declared torque could boast tolerances.

Article no.			Torque in N.m.
Series	Execution	Material	
		Raw Stainless steel	
150.SFTH	-03-9	.30	0,9
	-03-19	.30	1,9

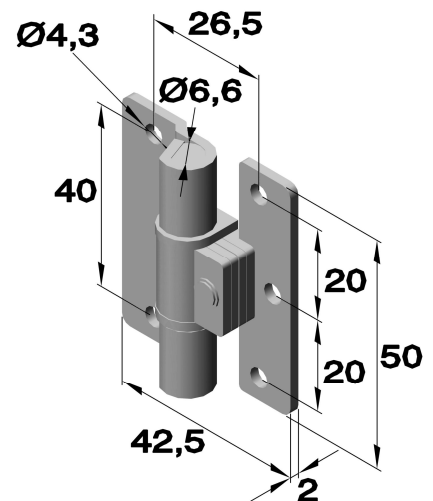

Art.no.: 150.SFTH (drilled)

with constant torque.

Operating temperature: -20°C ~ 60°C

The declared torque could boast tolerances.

Article no.			Torque in N.m.
Series	Execution	Material	
		Raw Stainless steel	
150.SFTH	-05-35	.30	3,4
	-05-58	.30	5,7

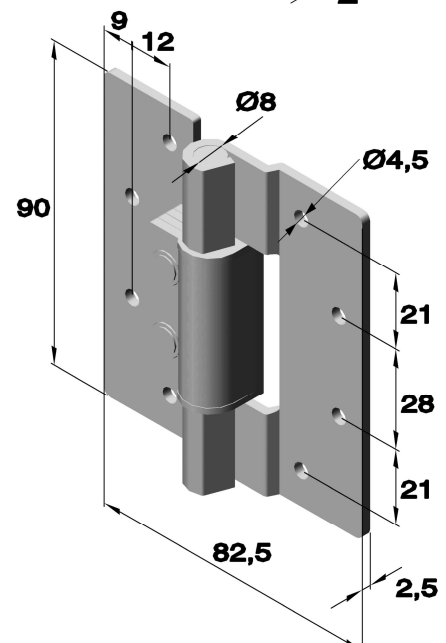

Torque hinges

Art.no.: 150.HG-TA (drilled)
with constant torque.

Operating temperature: 0°C ~ 40°C

The declared torque could boast tolerances.

Article no.			Torque in N.m.	Dimension in mm						
Series	Execution	Material		A	B	C	D	E	F	ØS
		Raw Stainless steel								
150.HG-TA	20L (Left)	.30	2	18,5	66	2	18	13	27	4,3
	20R (Right)	.30								
	30L (Left)	.30	3							
	30R (Right)	.30								
	45L (Left)	.30	4,5							
	45R (Right)	.30								

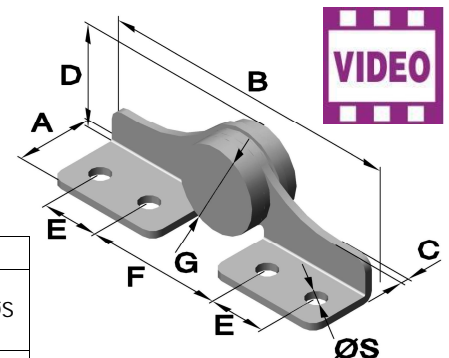

Art. no.: 150.HG-TB (perforated and countersunk)
with constant torque.

Operating temperature: 0°C ~ 40°C

The declared torque could boast tolerances.

Article no.			Torque in N.m.
Series	Execution	Material	
		Raw Stainless steel	
150.HG-TB	7L (Left)	.30	0,7
	7R (Right)	.30	
	20L (Left)	.30	2
	20R (Right)	.30	
	30L (Left)	.30	3
	30R (Right)	.30	

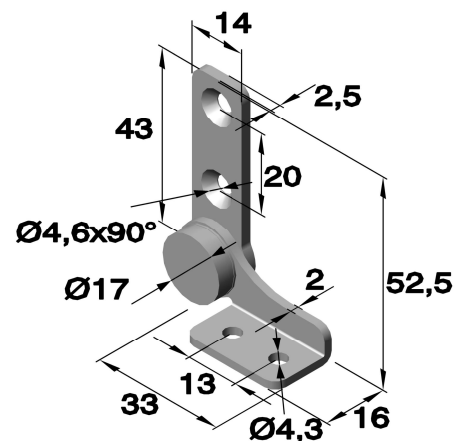

Art. no.: 150.HG-TB (perforated and countersunk)
with constant torque.

The declared torque could boast tolerances.

Article no.			Torque in N.m.
Series	Execution	Material	
		Raw Stainless steel	
150.HG-TB	45L (Left)	.30	4,5
	45R (Right)	.30	

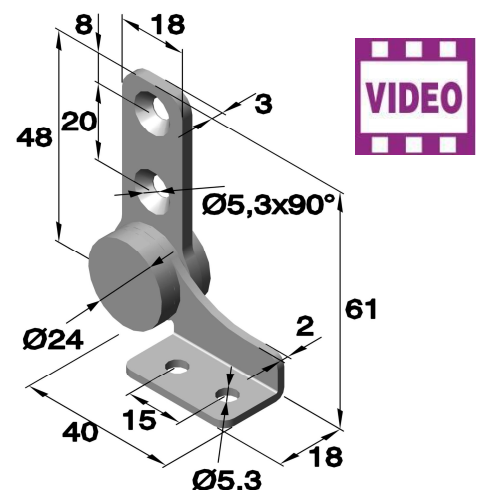

Torque hinges

Art. no.: 150.HG-IT (perforated)
with constant torque.

Operation temperature: -10°C ~ 50°C
Opening angle: ca. 190°

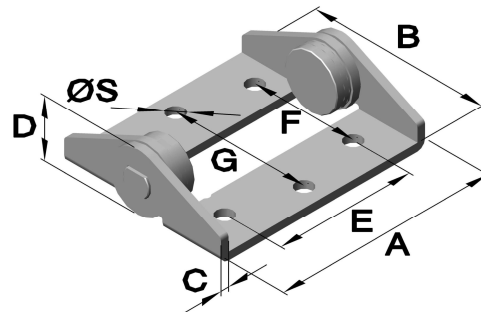

The declared torque could boast tolerances.

Article no.				dimension in mm							
Series	Execution	Material	Torque in N.m.	A	B	C	D	E	F	G	ØS
		Raw Stainless steel									
150.HG-IT	S25	.30	2,5	54	44	2	15,5	34	26	34	4,3
	S35	.30	3,5								
	SF	.30	Free running								
	M50	.30	5,0	54	80	2	25	34,8	36	66	5,3
	M70	.30	7,0								
	MF	.30	Free running								

Cover for Art.no.: 150.HG-IT

Article no.		Material
Serie	Execution	Silver
150.HG-IT	SC	ABS
150.HG-IT	MC	ABS

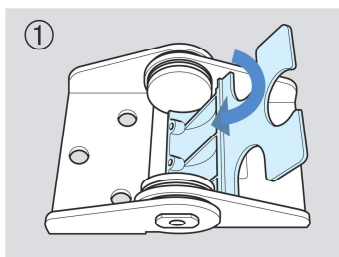

1. Insert the cover A under the hinge shaft.

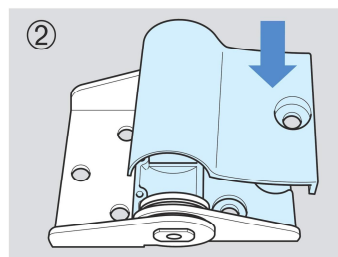
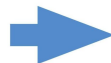

2. Put the cover B on the cover A.

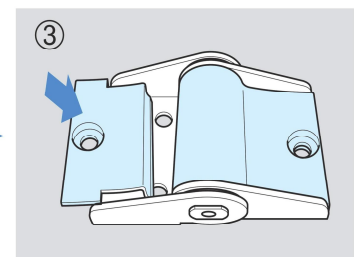
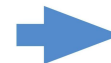

3. Put the cover C.

Torque hinges

Art.no. 6493 (perforated)

Hinge for invisible fence with constant torque.

Only for indoor applications.
Can be used horizontally or vertically.

The declared torque could boast tolerances.

Article no		Material		Torque in N.m.
Series	Execution	Raw	Stainless steel	
		6493		

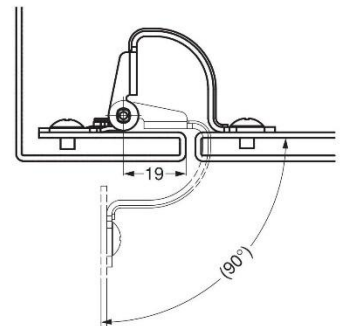
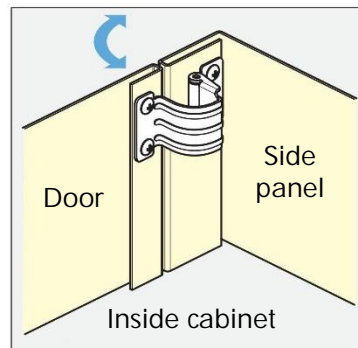
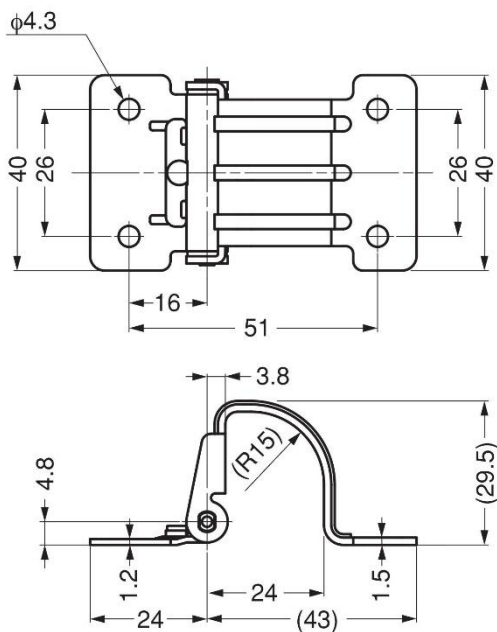

Torque hinges

Art. Nr.: 150.HG-TUWA (perforated)

Concealed hinge
with fence and constant torque.

Opening angle (130°).

Can be used horizontally or vertically.

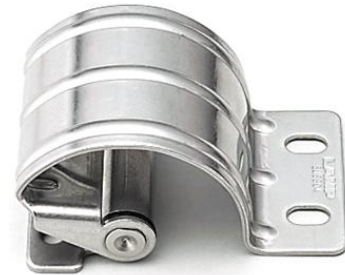

Article no			Torque in Nm
Series	Execution	Material Polished Stainless steel	
150.HG-TUWA	07	.33	0.7
150.HG-TUWA	15	.33	1.5

Anwendungsbeispiel

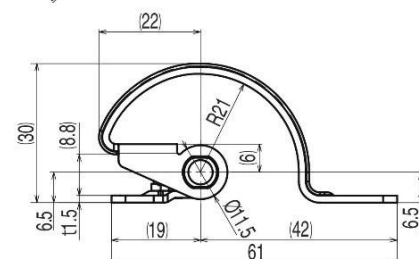
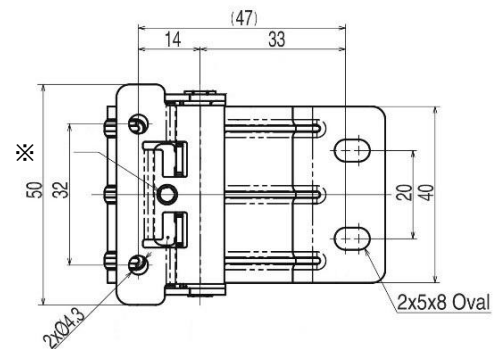
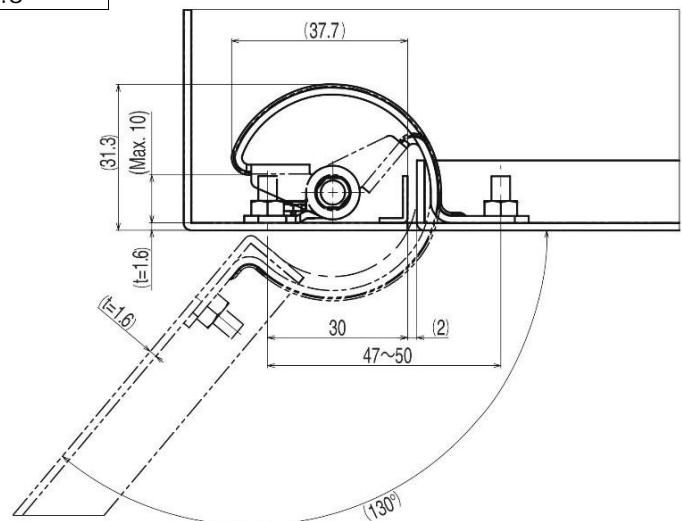
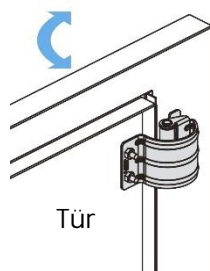
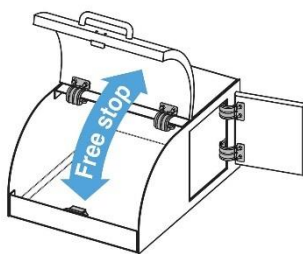
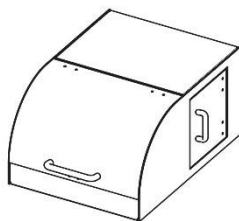

Torque hinges

Art.no.: 150.HG-T30.S15 (perforated)



Dual axis torque hinge
Operating temperature: 0°C ~ 40°C

Provides torque stability in both directions.

Suitable for monitor screens.



Series	Article no.		Torque N/m	
	Material	.30	tilting	swivelling
	Polished			
150.HG-T30.S15	Stainless steel		3	1,5

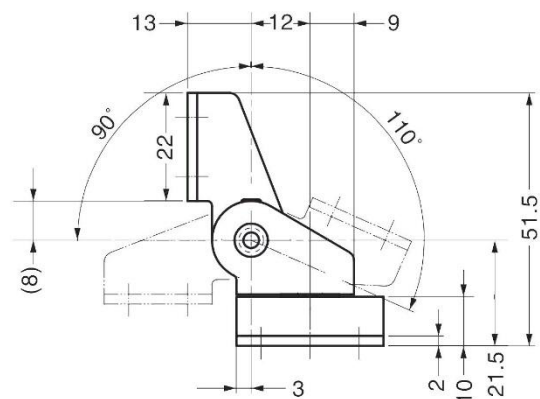
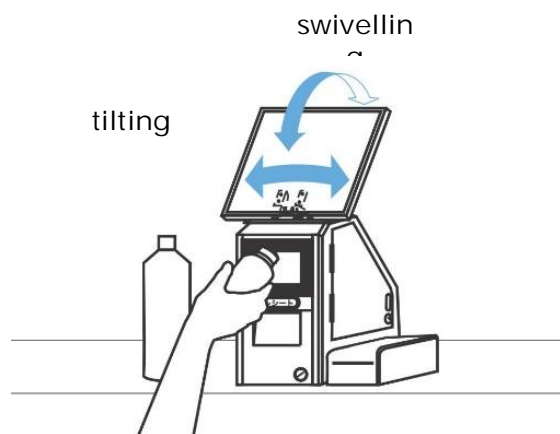
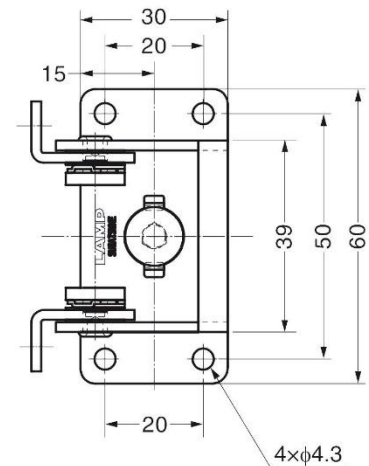
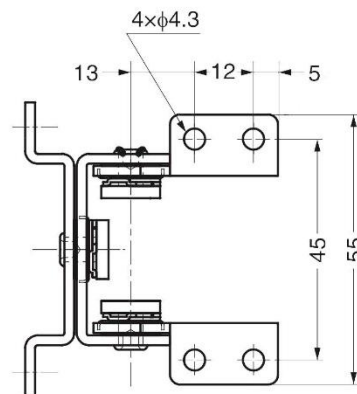

Torque hinges

Art.no.: 150.HG-T70.S30 (perforated and countersunk)



Dual axis torque hinge
Operating temperature: 0°C ~ 40°C

Provides torque stability in both directions.

Tilting: $\pm 30^\circ, \pm 90^\circ$
Swivelling: $0^\circ \sim 120^\circ$

Suitable for monitor screens.



Series	Article no.		
	Material	Torque N/m	
	Polished	tilting	swivelling
150.HG-T70.S30	Stainless steel	7	3
	.30		

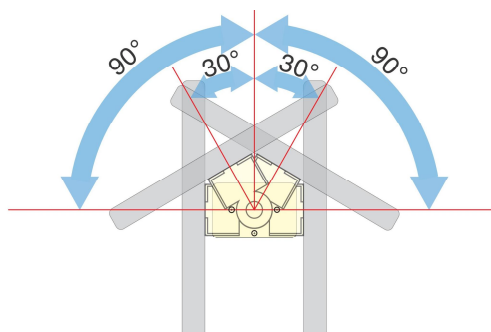
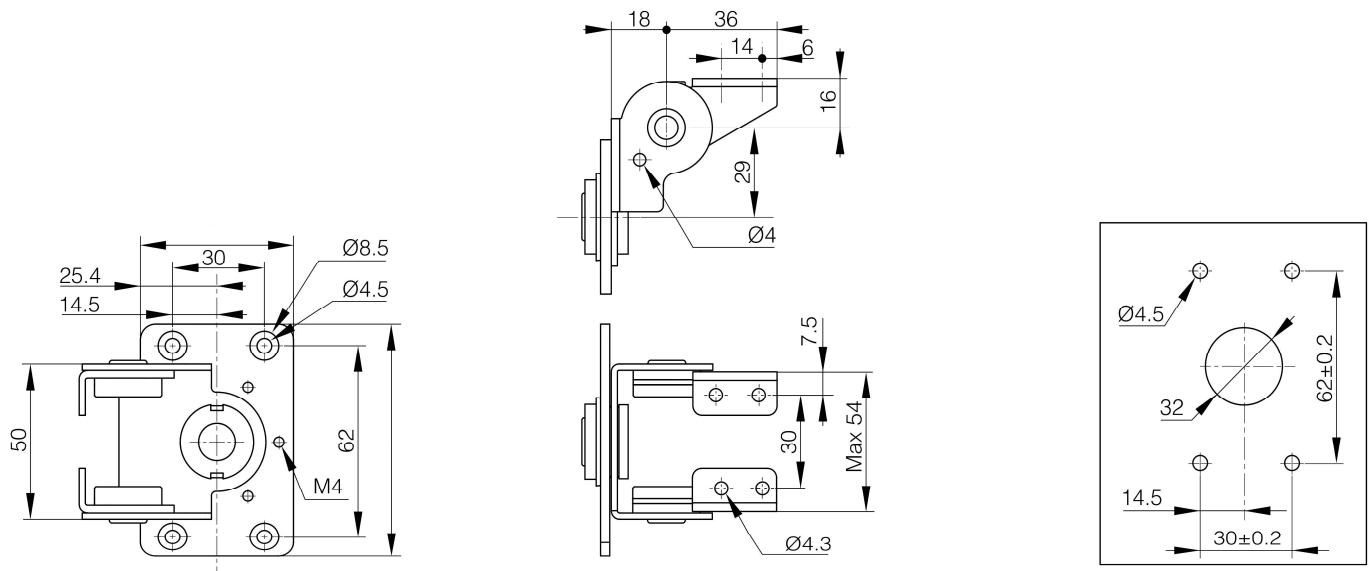

tilt

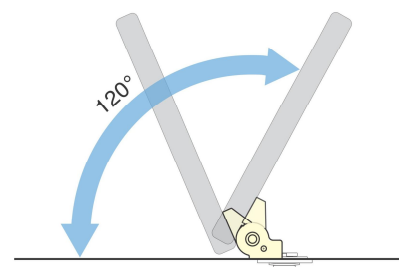

swivel

Torque hinges

Art. no.: 150. KA-T100S50

Monitor bracket with torque and auxiliary lock

Swivelling 180°, Tilting 40°.

Applicable monitor size: 12 ~ 22,9 Zoll (up to about 10,0 kg)

Can be quickly installed and removed.

Lock temporarily releases if a heavy load is applied when locked.

Do not forcibly move the monitor after applying the auxiliary lock!

After installing the monitor, make sure that the release lever is locked.

Do not operate continuously.

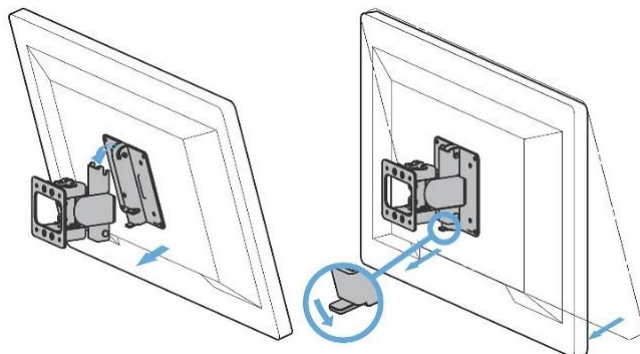

The monitor be installed with one touch.

Push down the release lever and lift the monitor, then the monitor can be removed.

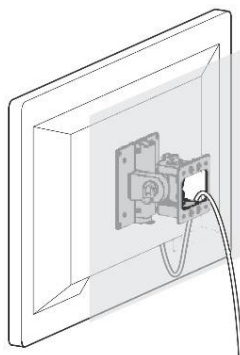

Wire holes allows you to put power cable and monitor cable out off the mounting surface.

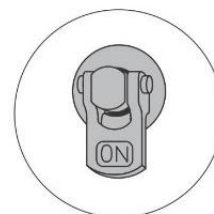
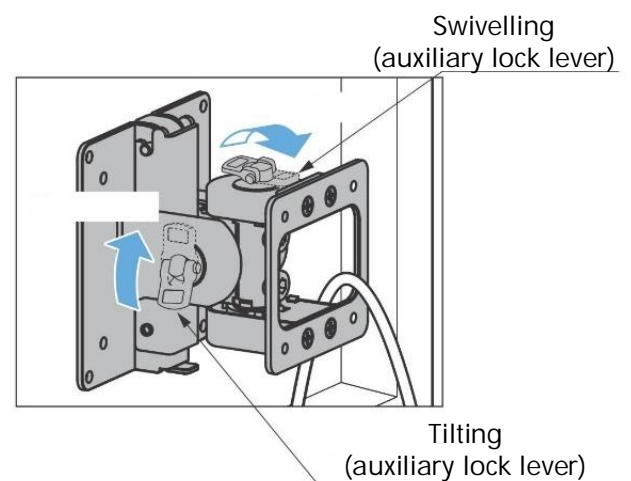

Locked



Released

Torque hinges

Art. no.: 150. KA-T100S50

Monitor bracket with torque and auxiliary lock

Released

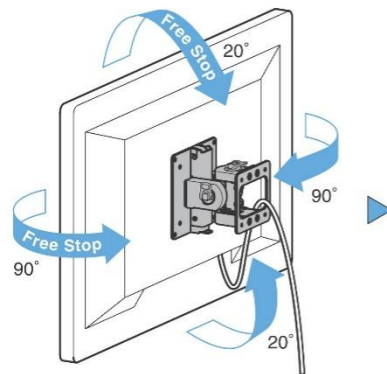

Locked

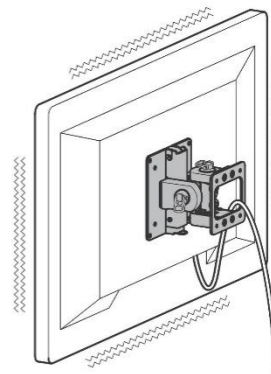

Can hold at any angle within $\pm 20^\circ$ in tilting and $\pm 90^\circ$ in swivelling.

Keeps the monitor in position even while subject.

Tilting
Auxiliary lock lever
(released)

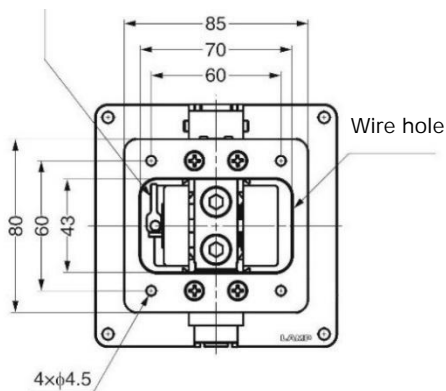

Swivelling
Auxiliary lock lever
(released)

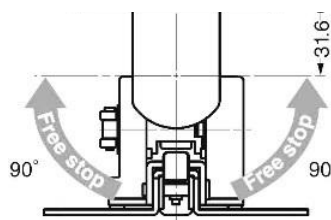
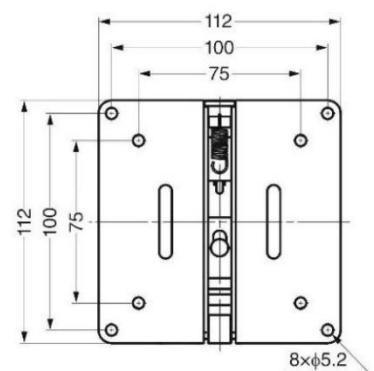
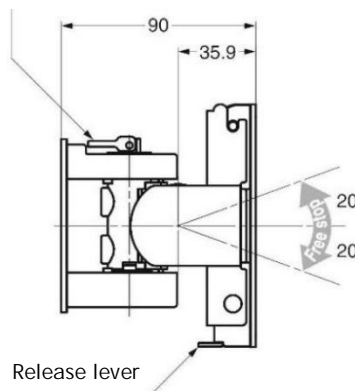

Torque hinges

Art. no.: 150.KA-150

Monitor bracket with constant torque.
Including hex key (for fixing the mounting base)

Monitor mount is used for moving
and adjusting monitor position.

Durability varies depending on operating environment and
frequency.

Total length can be changed by adjusting the pole length.
Ball-shaped holding part allows adjusting to any angle
(loosen the screw and adjust).

Do not apply load on display when using!

Other length on request.



on request

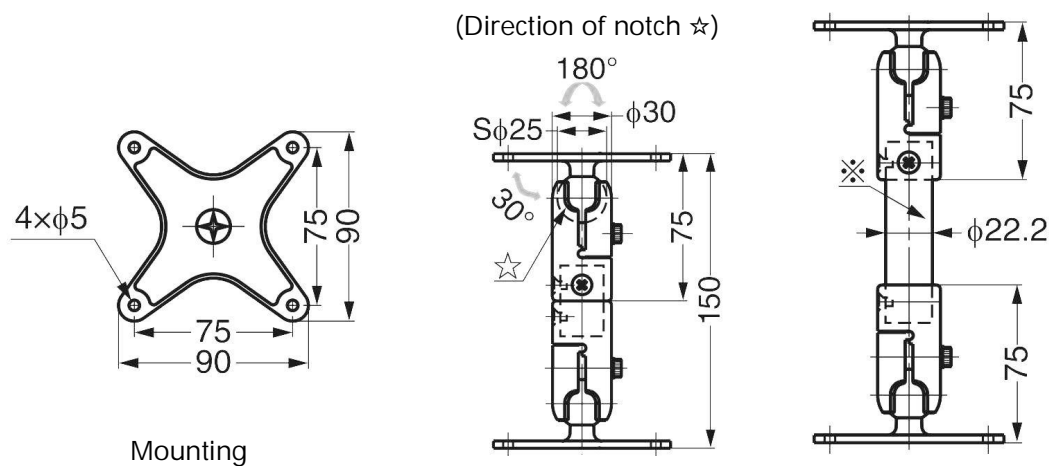
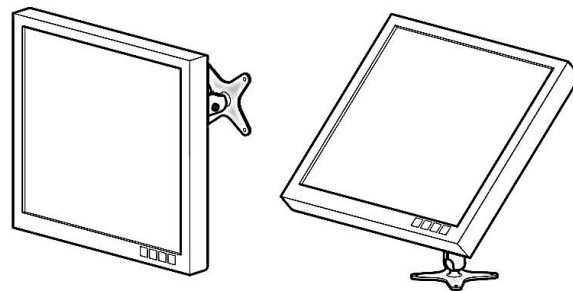

Torque hinges

Art. no.: 150. TV

Monitor bracket „for wall mounting“

Used to fix a small display on the wall
(max. 8 kg)

Adjustable type (150.TV-410SK)
can adjust the angle of the display about 20 °
from the vertical state to the front.

Durability varies depending on operating environment
and frequency.

Do not apply load on display when using!

Fixed type:
150.TV-400SK

Adjustable type:
150.TV-410SK

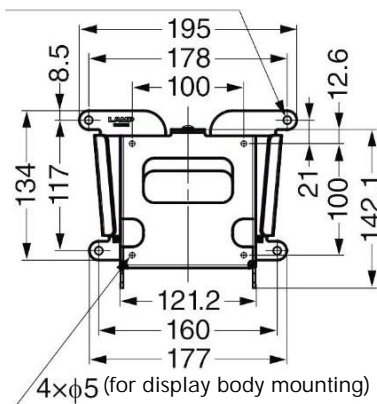

150.TV-400SK

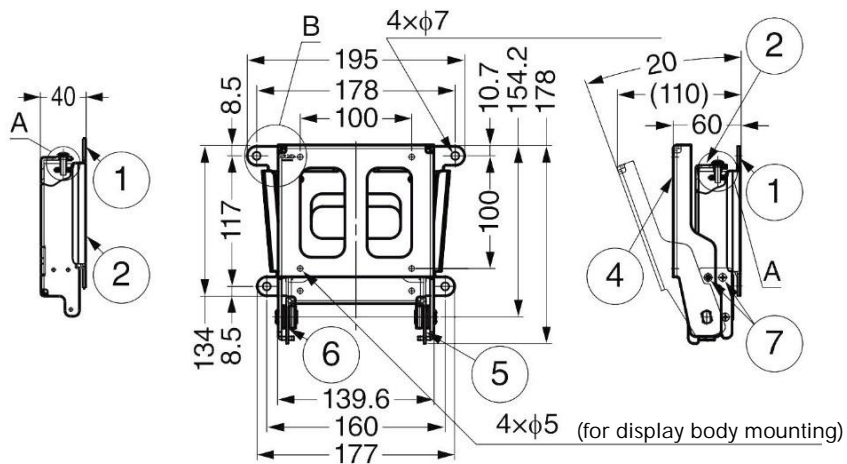

150.TV-410SK

1	Bracket
2	Fixed plate
3	Fall- preventing washer
4	Adjustable plate
5	Hinge R
6	Hinge L
7	Countersunk head machine screw
8	Washer faced pan head screw
9	Socket

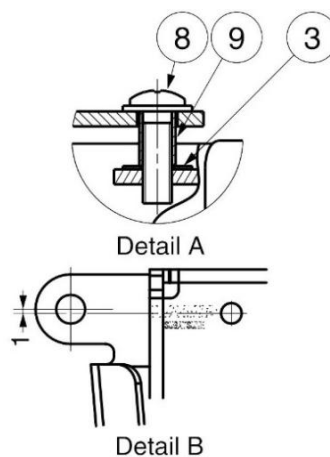

Installation (adjustable type)



Torque hinges

Art. no.: 150.HG-TQJ100 (perforated)

Adjustable one way torque hinge.

Operating temperature: 0 ~ 40 ° C
Opening angle ca. (248°).

Allows for frictionless handling of the door in the opposite direction.

Use a hex key (nominal size 5) for torque adjustment.

Use all mounting holes.

Do not remove the torque adjustment screw!

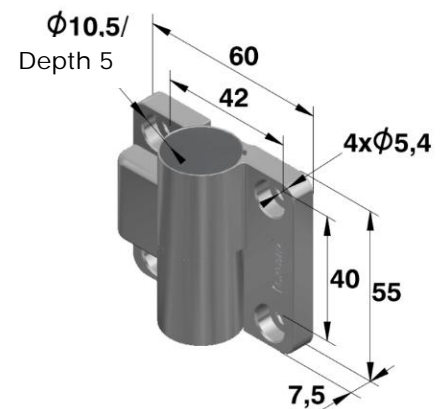

Article no.			Torque in Nm
Series	Execution	Material	
		Zamak Satin chrome	
150.HG-TQJ100	-A	.53	0~10
150.HG-TQJ100	-B	.53	

Torque working direction

Opening
150.HG-TQJ100-A

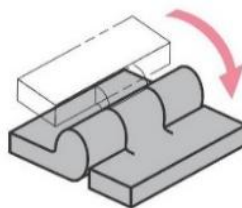

Closing
150.HG-TQJ100-B

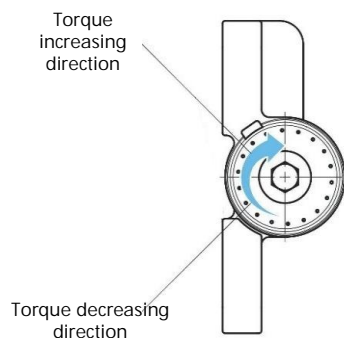
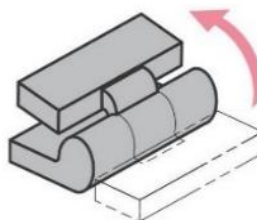

Application example



Since torque is adjustable from 0 to 10Nm, applicable to various doors.

Torque hinges

Art. no.: 150.HG-ITJ4080 (perforated)

with adjustable torque

Operating temperature: 0 ~ 40 ° C
Opening angle: (265°).

To prevent accidental fall of door or lid, minimum torque is set at 4Nm.

Use a spanner (nominal size 13) for torque adjustment.

Do not forcibly remove the torque adjustment nut!

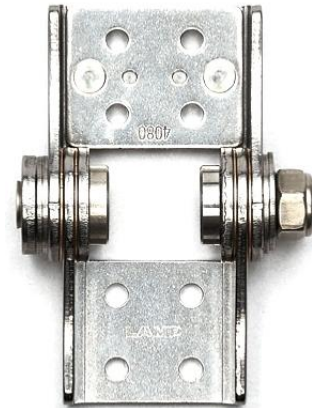

Article no.		Torque in Nm
Series	Material	
150.HG-ITJ4080	Barrel polished	4 ~ 8
	Stainless steel .30	

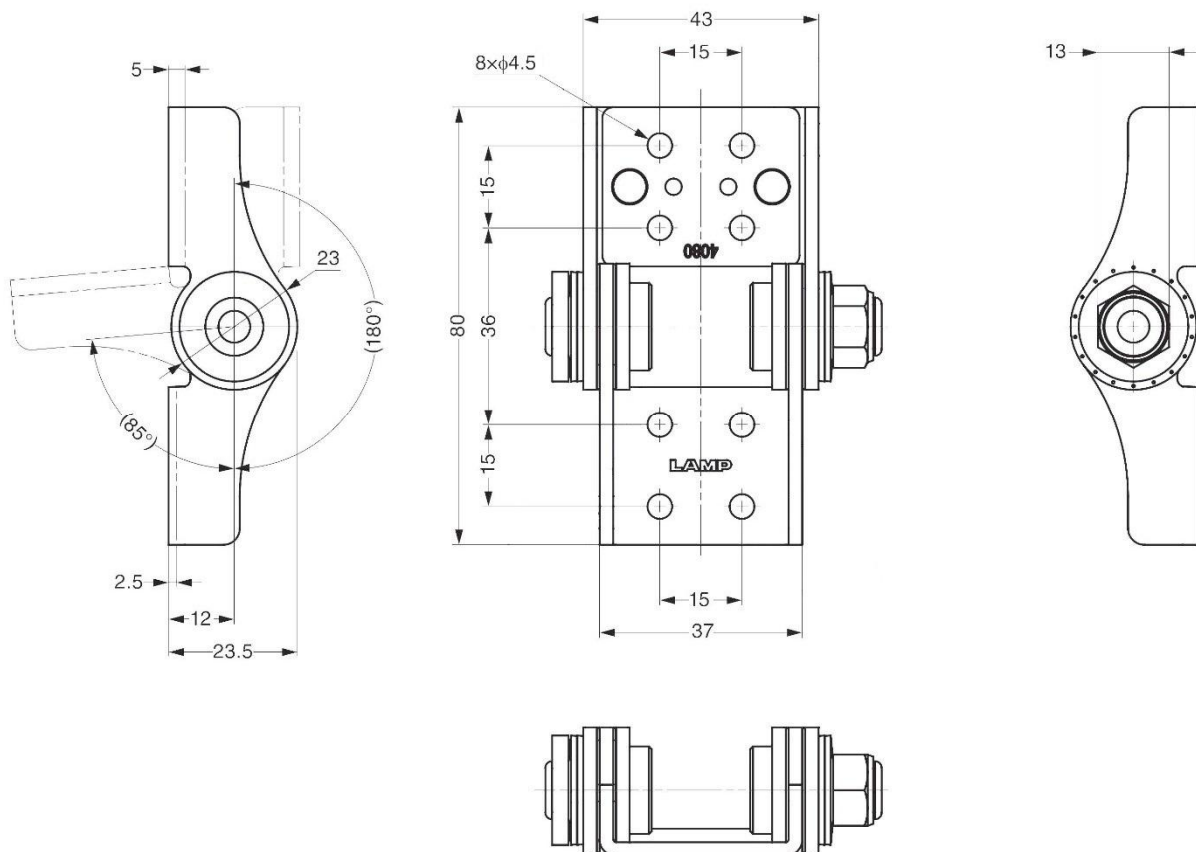

Torque hinges

Art. no.: 150.HG-ITHP (perforated)

with constant torque

Operating temperature: 0 ~ 100 ° C

Opening angle: ca. (269°).

Suitable for use in heat-generating environment.

Torque may decrease during and after heating.



Series	Article no.		Torque in Nm
	Execution	Material	
		Barrel polished Stainless steel	
150.HG-ITHP	07	.30	0.7
150.HG-ITHP	15	.30	1.5
150.HG-ITHP	30	.30	3.0

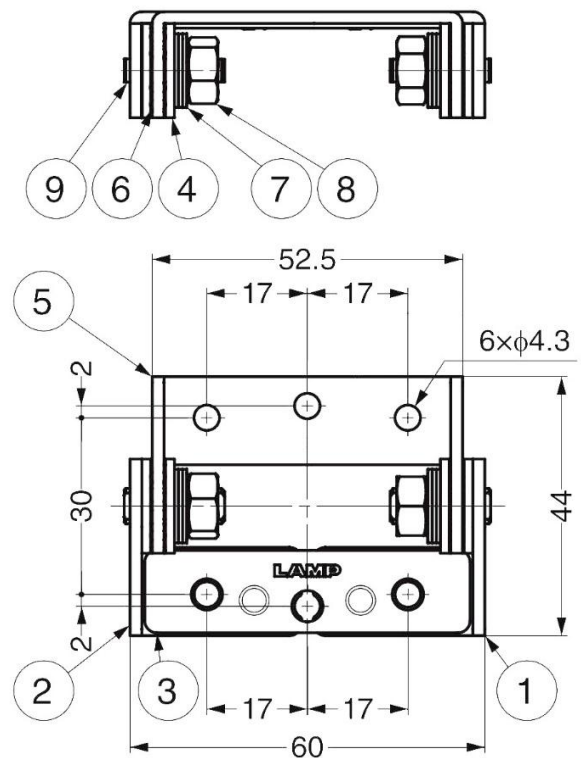
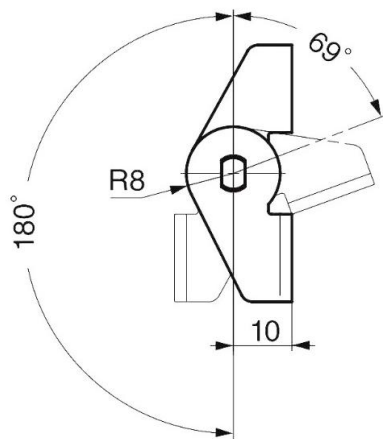

1	Base L
2	Base R
3	Connecting bracket
4	Thrust plate
5	Movable plate
6	Ball
7	Spring washer
8	Hexagon nut
9	Shaft

Torque hinges

Art. no.: 150.HG-TLS30-50-300 (perforated)

Piano hinge with constant torque.

Opening angle ca. (295°).

Do not cut!



Article no.		
Series	Material	Torque in Nm
	unbehandelt Stainless steel	
150.HG-TLS30-50-300	.30	3

Application example

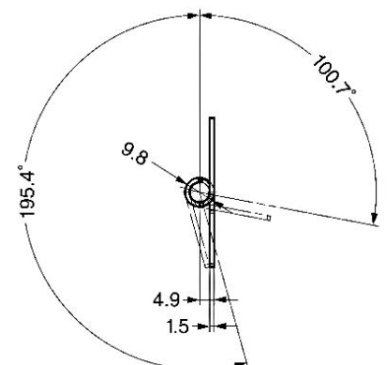
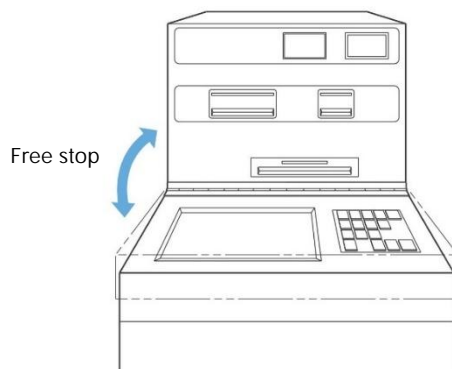

Torque hinges

Art. no.: 150.HG-DTB (perforated and countersunk)



Operating temperature: 0 ~ 40 ° C
Opening angle ca. (168°).

For pair using: Please use the same torque in both hinges.



Article no.			Torque in Nm	Detent moment* in Nm
Series	Execution	Material		
		Polished Stainless steel		
150.HG-DTB	4-R (Right)	.33	0.4	0.7
150.HG-DTB	4-L (Left)	.33		
150.HG-DTB	8-R (Right)	.33	0.8	1.5
150.HG-DTB	8-L (Left)	.33		

* Torque required to release detent.

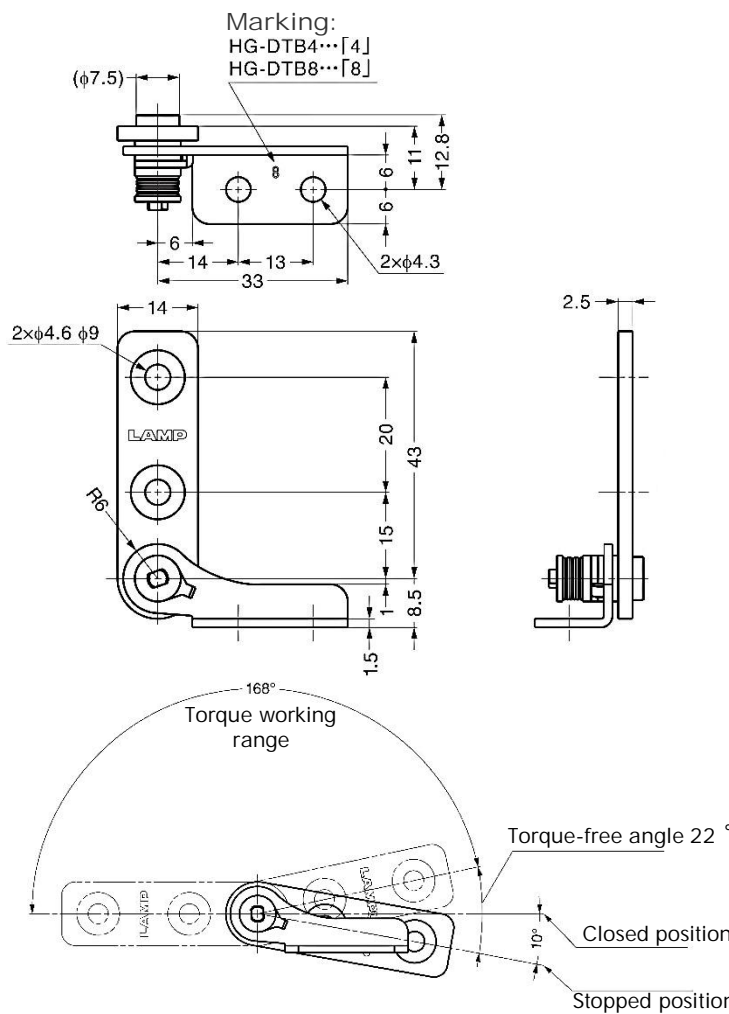

Application example

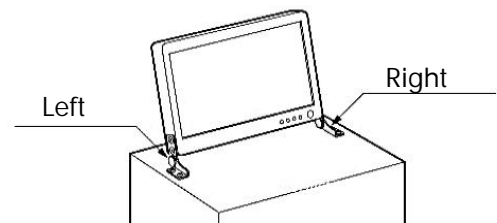

Detent function prevents spring-back in closed position.

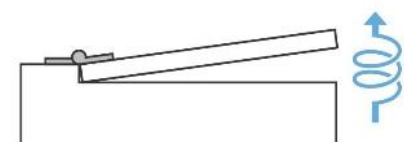

Left handed type shown. Right-handed type is symmetrical.

Torque hinges

Art. no.: 150.HG-TASJ40 (perforated)

with adjustable Torque

Operating temperature: 0 ~ 40 ° C
Opening angle ca. (269°).

Use a spanner (nominal size 13) for torque adjustment.

The factory setting of torque is 4,0 Nm

Do not forcibly remove the torque adjustment nut!

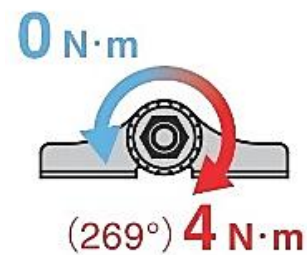

Article no.			Torque in Nm
Series	Execution	Material	
		Polished	0 ~ 4.0
		Stainless steel	
150.HG-TASJ40	R (Right)	.33	
150.HG-TASJ40	L (Left)	.33	

Application example

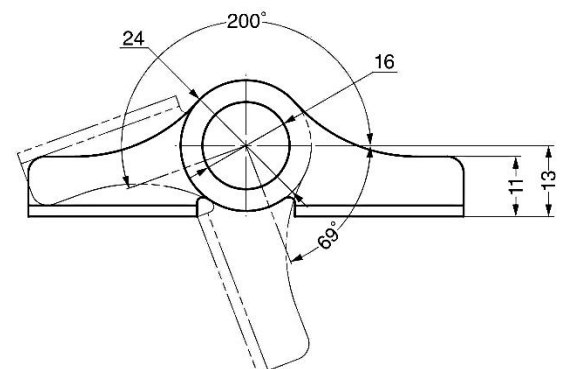
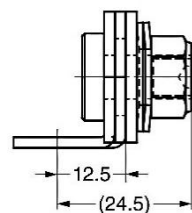
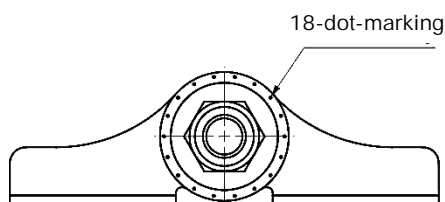
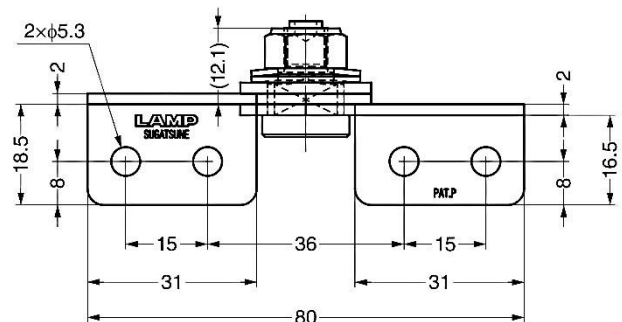
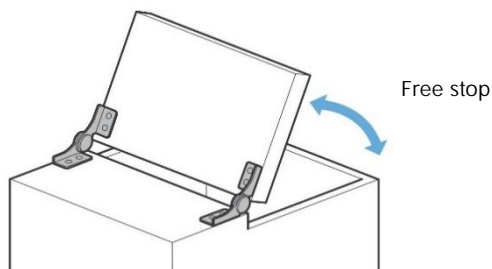

Left-handed type shown.

Torque hinges

Art. no.: 150.HG-TBSJ40 (perforated and countersunk)

with adjustable Torque

Operating temperature: 0 ~ 40 ° C
Opening angle ca. (270°).

Use a spanner for torque adjustment (nominal size 13).

Do not forcibly remove the torque adjustment nut!

The factory setting of torque is 4,0 Nm.

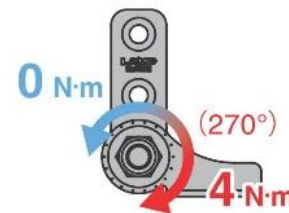

Article no.			Torque in Nm
Series	Execution	Material	
150.HG-TBSJ40	R (Right)	Polished	0~4.0
		Stainless steel	
150.HG-TBSJ40	L (Left)	.33	

Application example

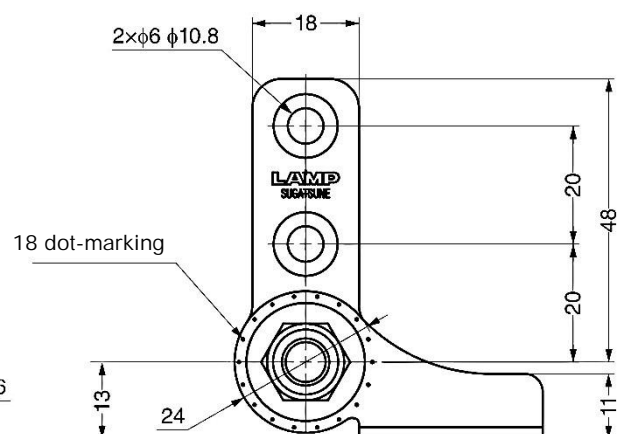
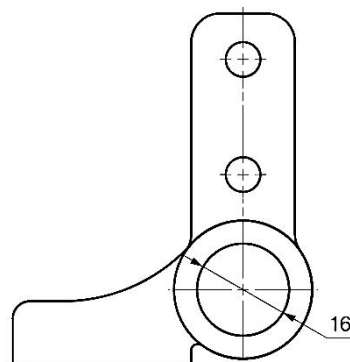
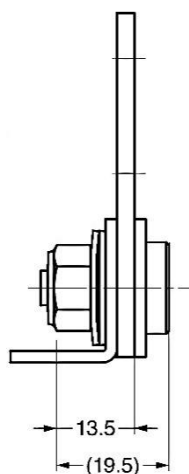
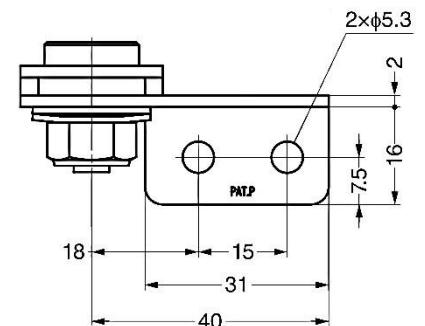
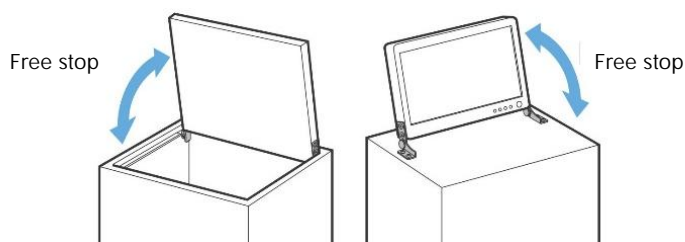

Left-handed type shown. Right-handed type is symmetrical

Torque hinges

Art. no.: 150.HG-RT (perforated and countersunk)

Opening angle (0° ~ 100°)
Operating temperature: 0 ~ 40 ° C

Torque decreases as the opening angle increases,
making easier to open the lid.

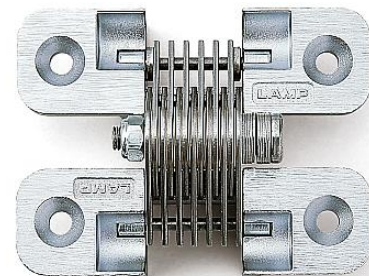

Article no.			Torque in Nm/Pair (closed position)
Series	Execution	Material	
150.HG-RT	30	Chromed Zamak	3
150.HG-RT	50	.53	5

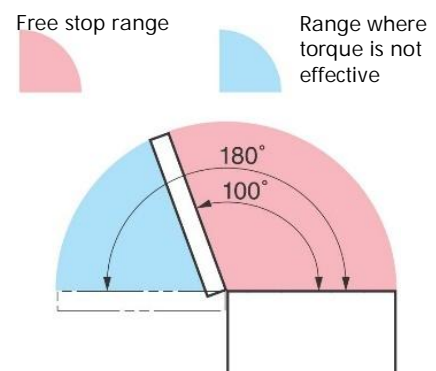
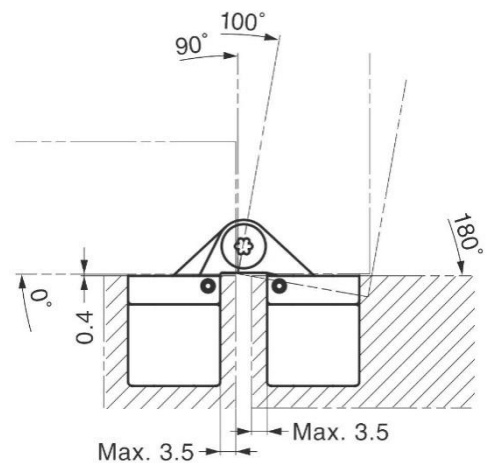
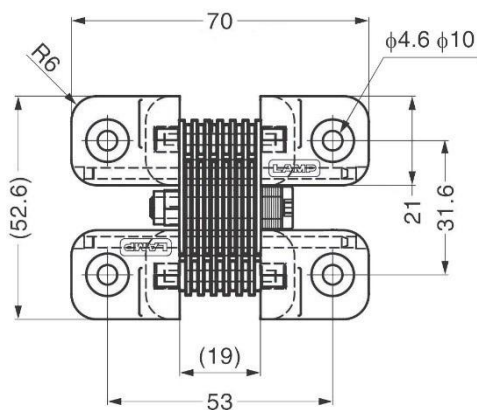
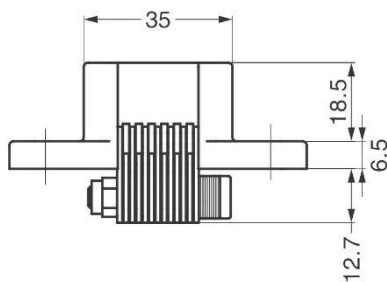

Torque hinges

Art. no.: 150.HG-KNT (perforated)

with constant Torque Lift-Off Typ.

Can be used vertically and horizontally.

When using the hinges horizontally, set the holders opposite each other to prevent them being inserted or removed.



Article no.			Torque in Nm
Series	Execution	Material Polished Stainless steel	
150.HG-KNT	3L (Left)	.33	0.3
150.HG-KNT	3R (Right)	.33	
150.HG-KNT	7L (Left)	.33	0.7
150.HG-KNT	7R (Right)	.33	
150.HG-KNT	16L (Left)	.33	1.6
150.HG-KNT	16R (Right)	.33	

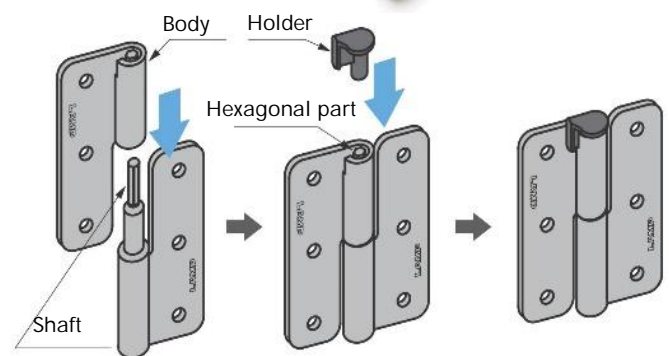

Install the body into shaft and then insert the holder into the hexagonal part of shaft to generate torque. To detach, use a tool to push the holder out.

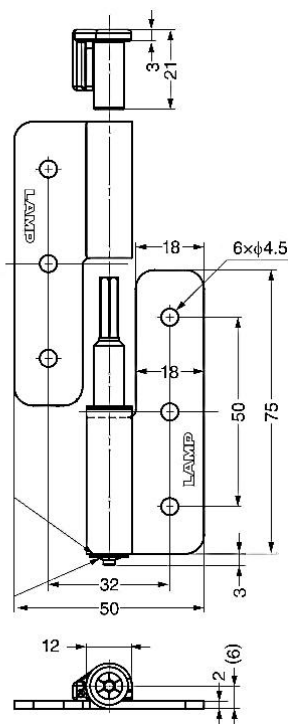

150.HG-KNT16L

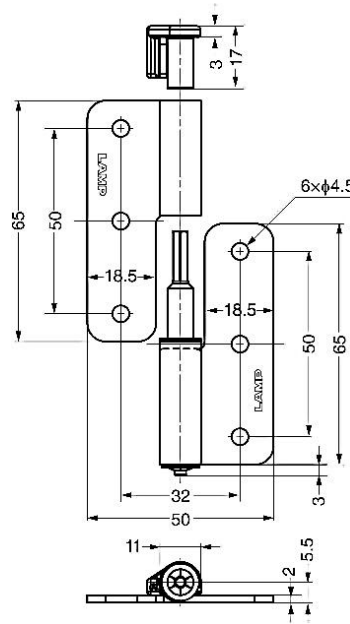

150.HG-KNT7L

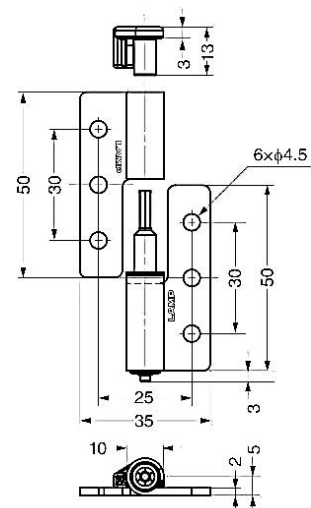

150.HG-KNT3L

Left-handed type shown. Right-handed type is symmetrical.

Torque hinges

Art. no.: 150.HG-TMH (perforated and countersunk)



Dual axis torque hinge

Swivels: 180°.

Suitable for folding table of shop and train.

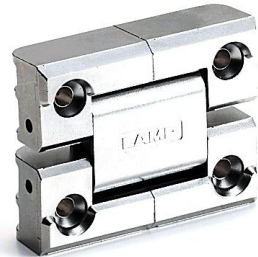

Article no.		Material			Torque in Nm	
Series	Execution	Zamak			Axis A	Axis B
		Chromed	Satin Nickel	Black		
150.HG-TMH	1530	.53	-SN.51	-BL.57	1.5	3.0
	2030	.53	-SN.51	-BL.57	2.0	

Hinge motions

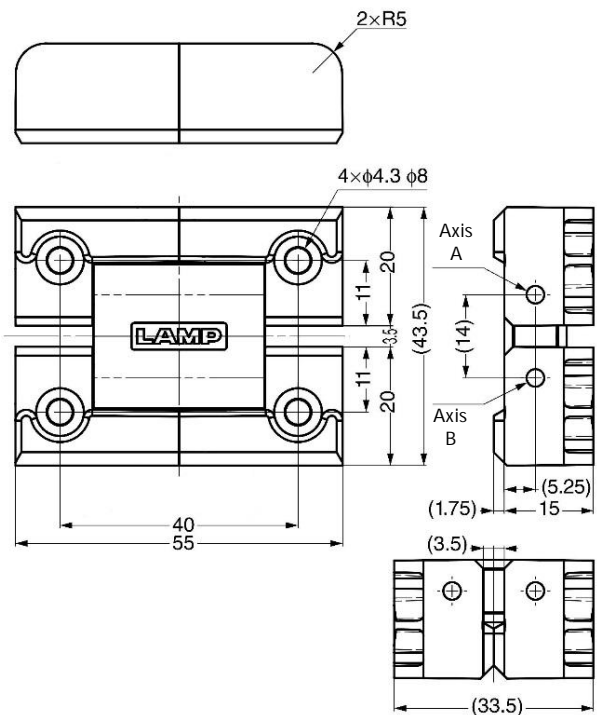
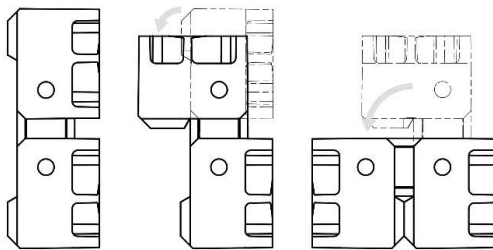
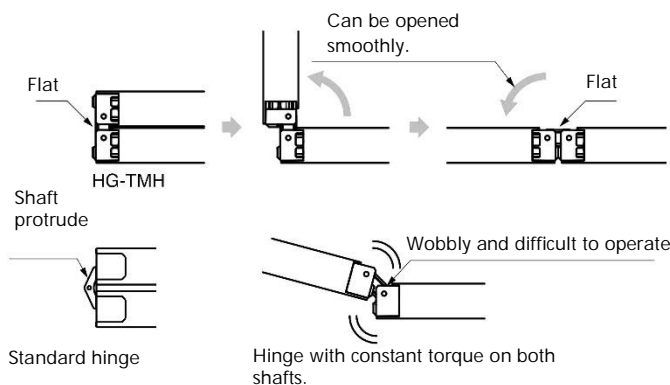
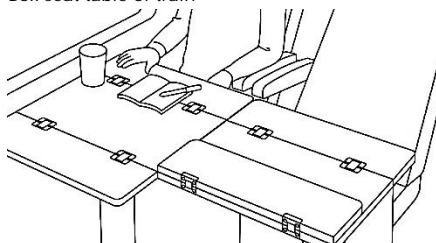

Table movement



Application example

Box seat table of train



When fully opened

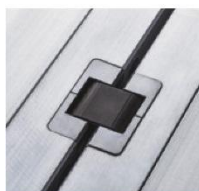

Flat and shafts do not protrude.



No projection from the top surface of the door when fully opened. The top of door is maintained as the mounting screws are not visible.

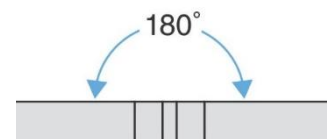

Torque hinges

Art. no.: 150.HG-JHW16S (perforated and countersunk)

with constant torque

Opening angle ca. (180°)

Operating temperature: 0 ~ 40 ° C

With built-in damper.

Covers various torque ranges by using „with damper“ and „without damper“ as a pair.

Install a stopper such as a stay at the lid opening/ closing position (0~ 120 degree) for not exceeding the specified swivelling range.

Do not disassemble or modify the product!



Article no.				
Series	Execution		Material	Torque in Nm
	Closing	Opening	Dark grey PBT	
150.HG-JHW16S	-34	-34G	.85	2.0 ~ 3.4
150.HG-JHW16S	-50	-50G	.85	3.4 ~ 5.0
150.HG-JHW16S	-00 without damper		.85	-

150.HG-JHW16S

150.HG-JHW16SG

Bottom view

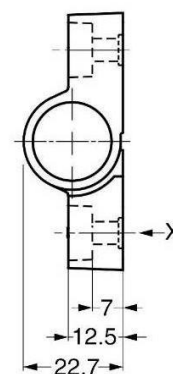
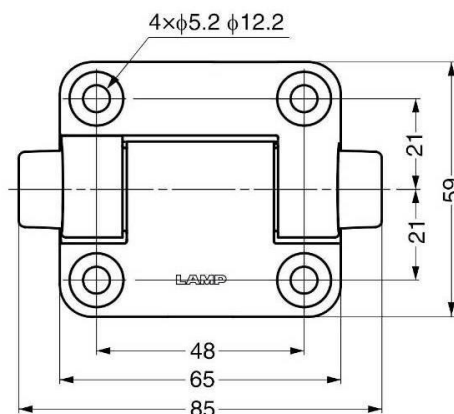
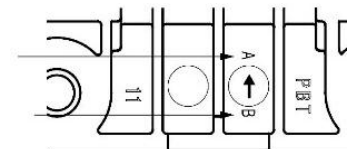

Damper working direction

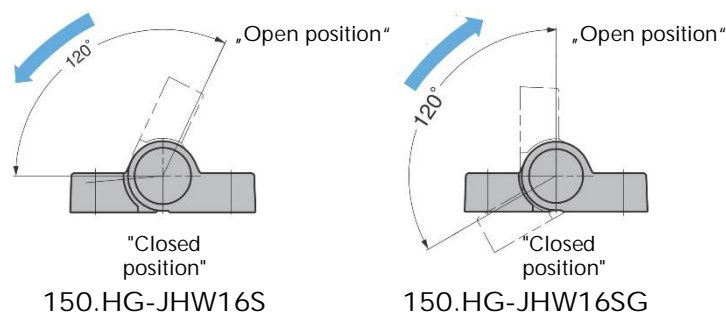

Torque hinges

Art. no.: 150.HG-JHW, HG-JHWG (perforated and countersunk)



with constant torque

Opening angle ca. (115°)

Hinge with built-in dampers.

Install a stopper such as a stay at the lid opening/closing position (0 ~ 115 degree) for not exceeding the specified swivelling range.



150.HG-JHW



150.HG-JHWG

Series	Article no.		Material Dark grey	Torque in Nm/Pair
	Execution			
	Closing	Opening	PBT	
150.HG-JHW	50	50G	.85	3 ~ 5
150.HG-JHW	70	70G	.85	5 ~ 7

Damper working direction

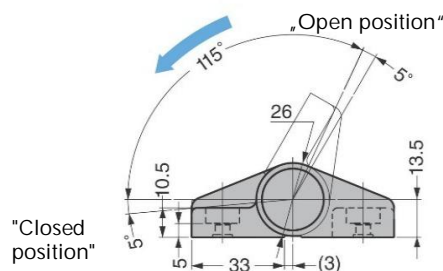

150.HG-JHW

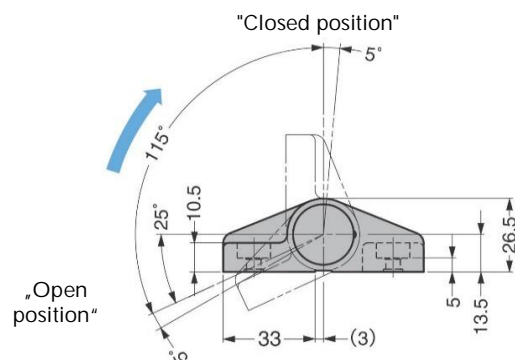

150.HG-JHWG

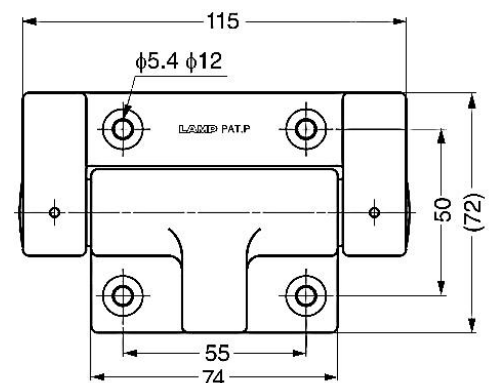
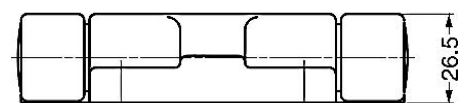

Torque hinges

Art. no.: 6879 (perforated)

with constant torque

Opening angle ca. (115°)

Hinge with built-in dampers.
Smooth movement in the opening direction.

Install a stopper such as a stay at the lid opening/ closing position (0 ~ 115 degree) for not exceeding the specified rotation range.

Sold in pairs.
Also be found in chapter: „Weld on hinges“.



White (Left-handed)

The damper works when rotating counterclockwise.

Article no.			Torque in Nm/Paar
Series	Execution	Material	
6879	.01	Dark grey	5 ~ 7
		PBT	
6879	.02	.85	3 ~ 5

Working working direction

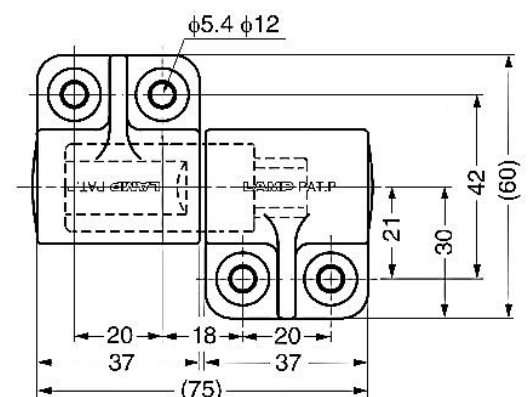
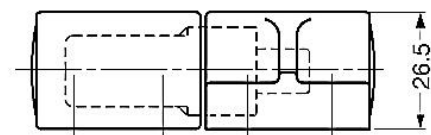
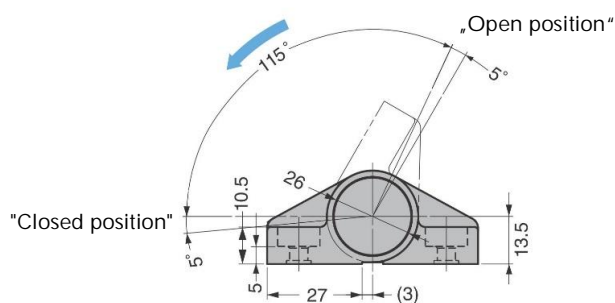

Left-handed type shown.

Torque hinges

Art.no: 6198

with constant torque
Friction in one direction only.

Operating temperature: 0°C~ 50°C
Torque will decrease at low temperature.

Not suited to vibration environment.

Sold in pairs.

		Article no.	
Series	Execution	Material	Torque in Nm/Pair
		Anodized Aluminium	
6198	.01	.70	9
6198	.02	.70	9

Shaft made of stainless steel; Covers made of „POM“

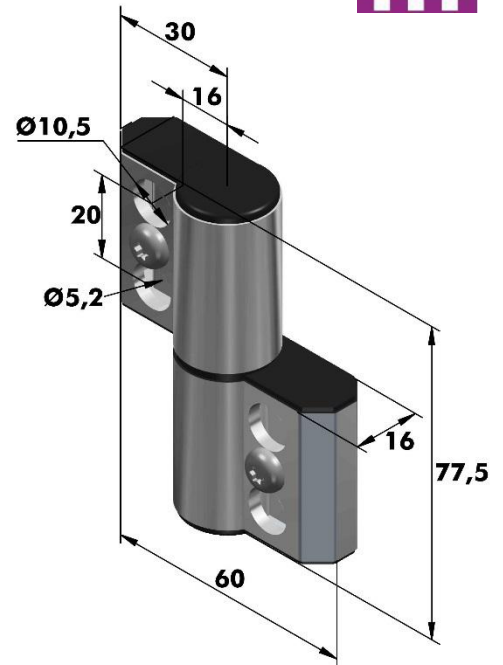

Torque and free stop range



6198.01.70

Range where torque is not effective,
install stopper to hold the door.

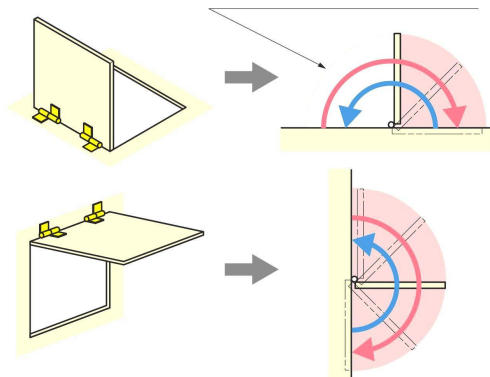

6198.02.70

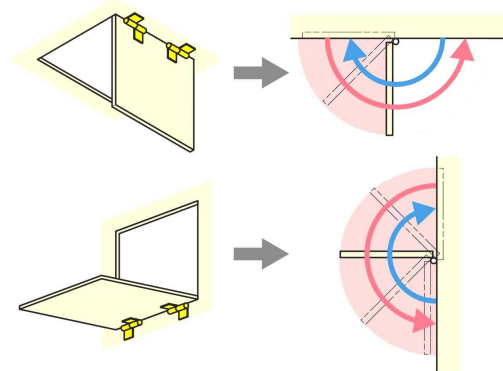

Torque hinges

Art. no.: 150.HG-JHM20 (perforated)

with constant torque

Mortise mount type.

Hinge with built-in dampers.

Smooth movement in opening direction.
Damper mechanism works when opening the lid about 60° or more.

Sold in pairs.

Minimum door thickness: 8mm

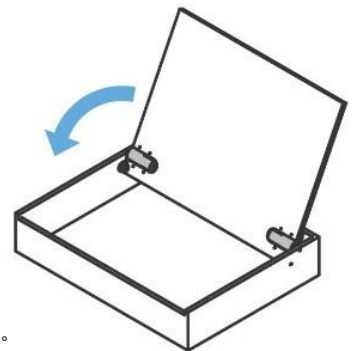

Article no.				Torque in Nm/Pair
Series	Execution	Material POM		
		Black	White	
150. HG-JHM20	-80	BL.87	WT.81	6~8

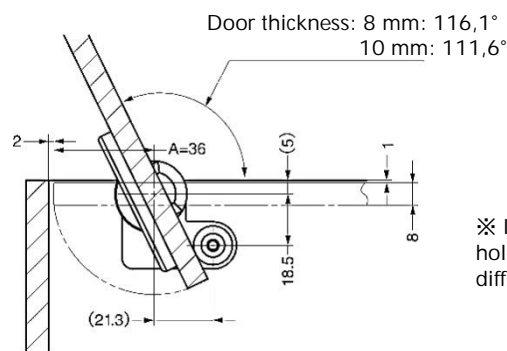
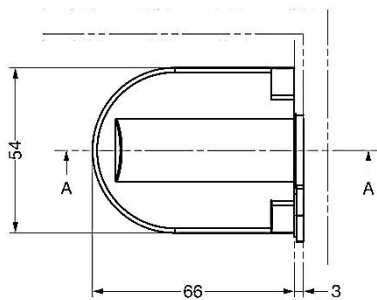

※ If the distance from the screw hole to the edge is 5mm, a level difference of 1mm is generated.

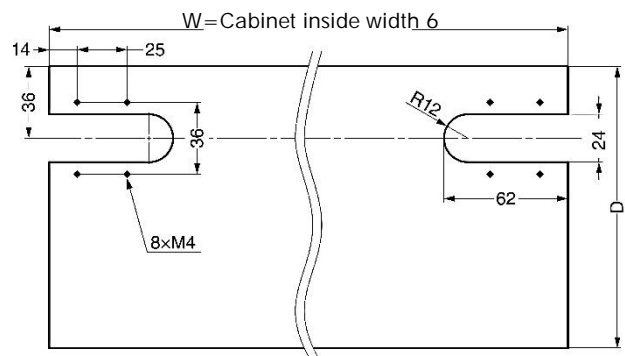
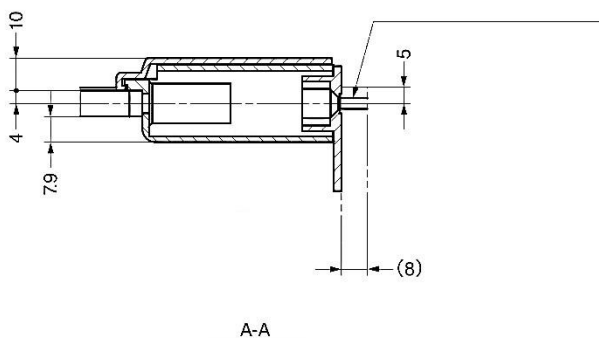

Torque hinges

Art. no.: 150.HG-JHM14 (perforated)

Hinge with built-in damper

Operating temperature: 0 ~ 40 ° C
Opening angle (105°)

Minimum door thickness: 8mm

Damper mechanism works when opening the lid by about 60 °.



Sold in pairs.

Series	Article no. Execution	Material		Torque in Nm/Pair
		POM		
		Black	White	
150. HG-JHM14	-S-8	BL.87	WT.81	0.5 ~ 0.8
150. HG-JHM14	-S-15	BL.87	WT.81	0.8 ~ 1.5
150. HG-JHM14	-S-20	BL.87	WT.81	1.5 ~ 2

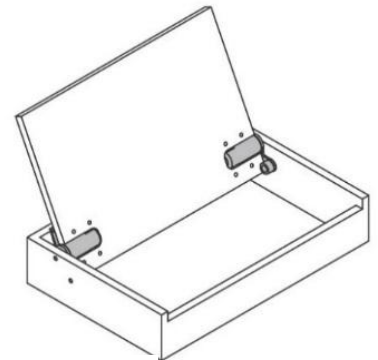

The installation example relates to a wooden cover.

W

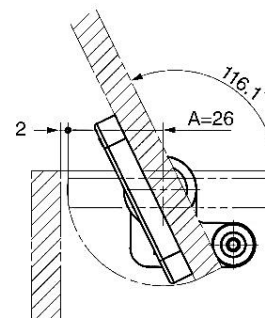
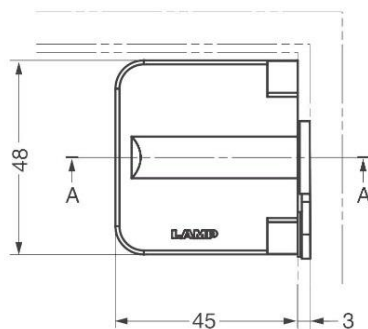

※ A level difference of 2mm will be generated.

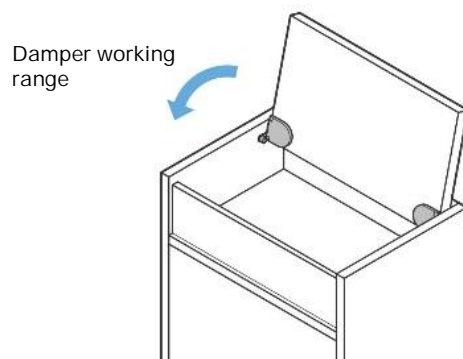

Cut out dimensions

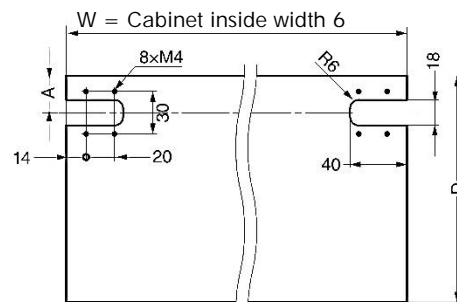

Torque hinges

Art. no.: 150.HG-JH14-50 (perforated and countersunk)

Soft-close hinge with damper and constant torque

Install a stopper such as a stay at the lid opening/closing position (0 ~ 115 degree) for not exceeding specified rotation range.

Sold in pairs.

Article no.		Torque in Nm/Pair
Series	Material	
150.HG-JH14-50	Mirror polished	3 ~ 5
	Stainless steel	

Low torque type (1,6 bis 3,0 Nm) on request.

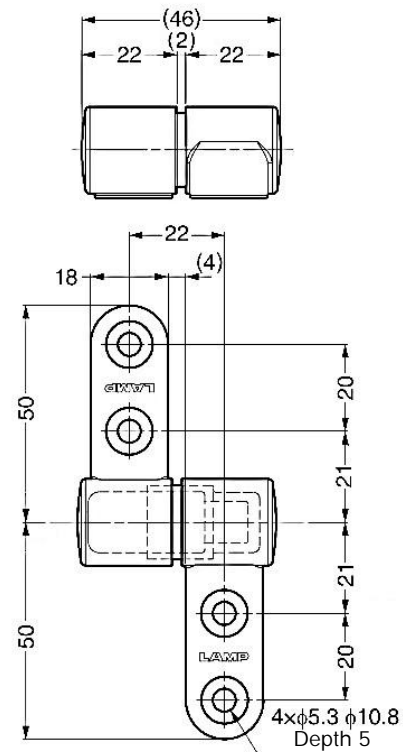
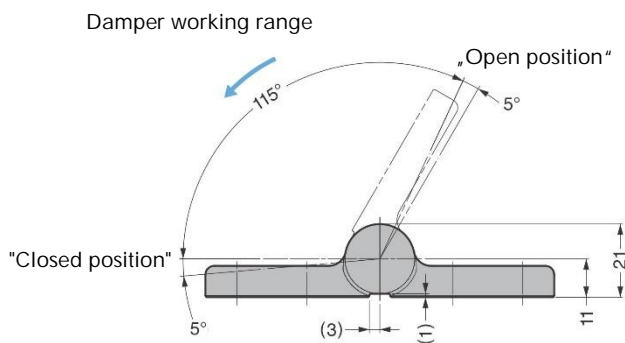

Left-handed type shown.

Torque hinges

Art. no.: 150.HG-JHM9-S (perforated and countersunk)



Hinge with built-in damper
Under mount type

Operating temperature: 0 ~ 40 ° C



Sold in pairs.

Series	Article no.		Torque in Nm/Pair
	Material		
	Black	White	
150. HG-JHM9-S	BL.87	WT.81	0.054~0.086
150. HG-JHM9-S4	BL.87	WT.81	0.027~0.043

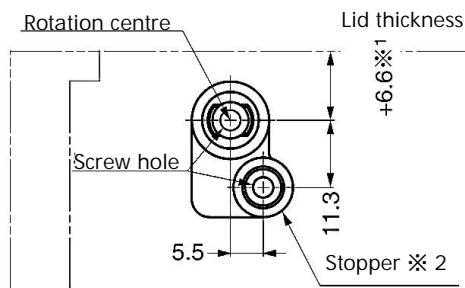

※ 1 Dimension when side board is flush with top surface of lid.

※ 2 To increase the opening angle of lid, rotate the stopper then fix it.

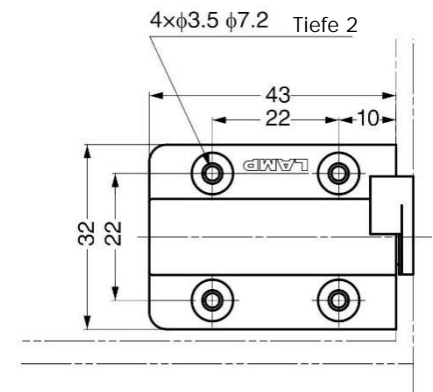

Cut out dimensions

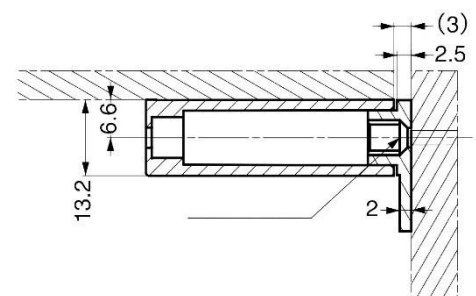
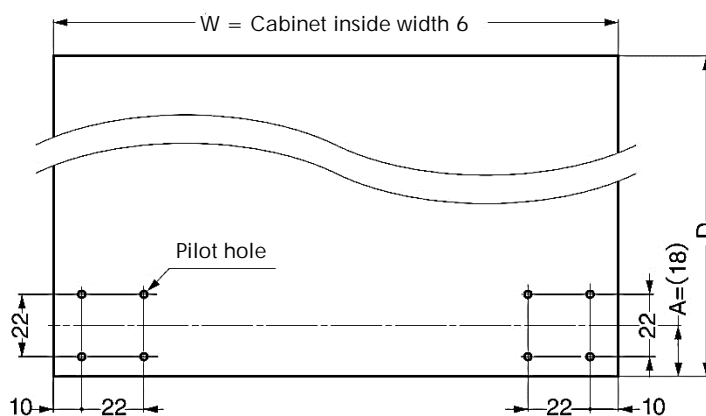

Torque hinges

Art. no.: 150.HG-JHM9-U (perforated and countersunk)



Hinge with built-in damper and constant torque.

Operating temperature: 0 ~ 40 ° C
Opening angle (105°)



Sold in pairs.

Series	Article no.		Torque in Nm/Pair
	Material		
	Black	White	
150. HG-JHM9-U	BL.87	WT.81	0.054~0.086
150. HG-JHM9-H4	BL.87	WT.81	0.027~0.043

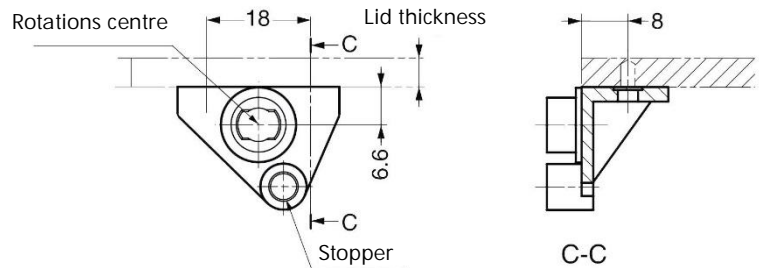
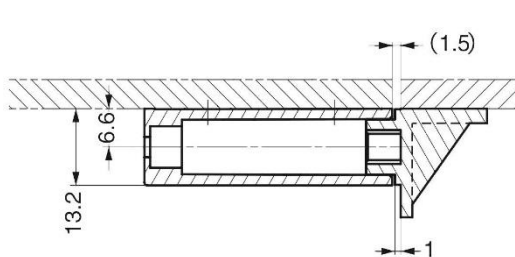

Cut out dimensions

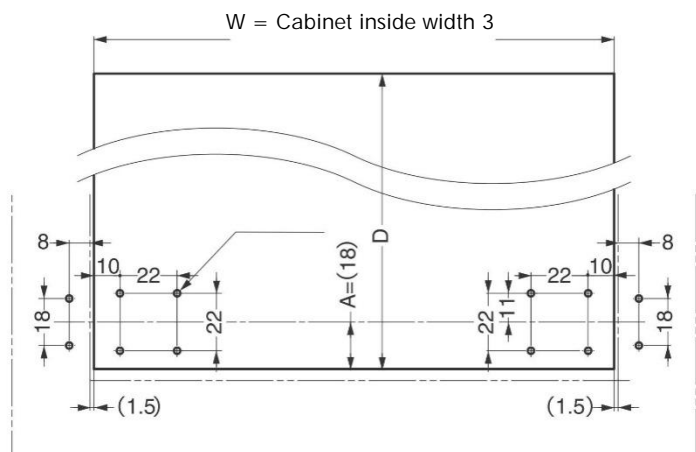
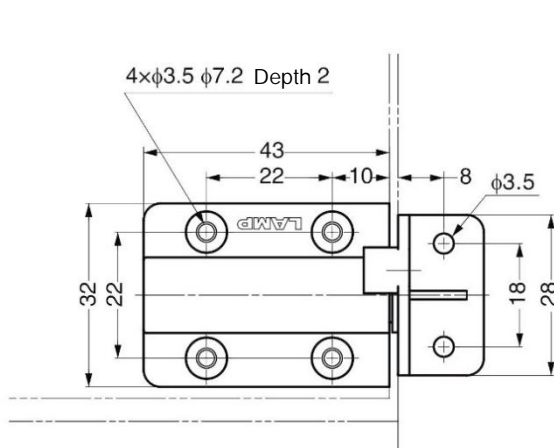

Torque hinges

Art. no.: 150.HG-JHS9-S (perforated and countersunk)

Small damper hinge with self-opening function for top-opening lids.

Operating temperature: 0 ~ 40 ° C
Opening angle (105°)

Opening speed is adjustable with a hex key.

Pressure cap sold separately.

Sold in pairs.

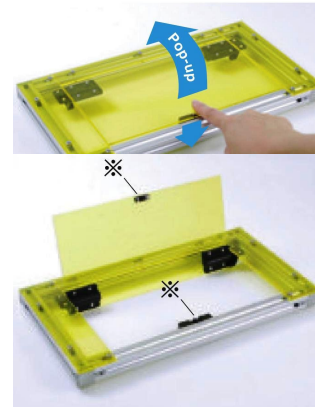

Series	Article no.		Torque in Nm/Pair
	Material		
	Black	White	
150. HG-JHS9-S	BL.87	WT.81	0.027~0.043

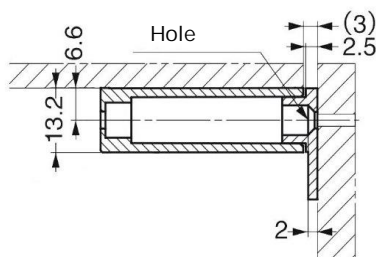

※ 1 Dimension when side board is flush with top surface of lid.

※ 2 To increase the opening angle of lid, rotate the stopper then fix it.

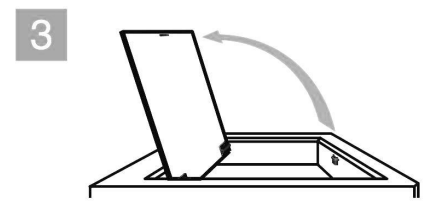
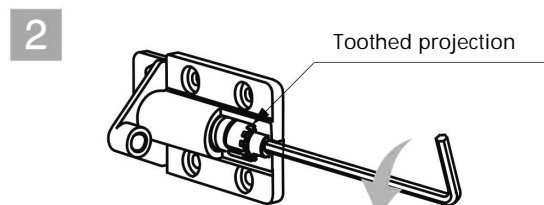
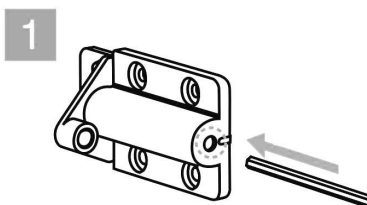
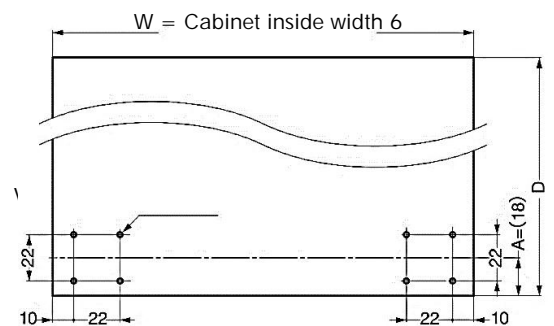
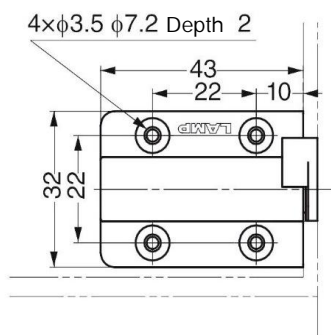
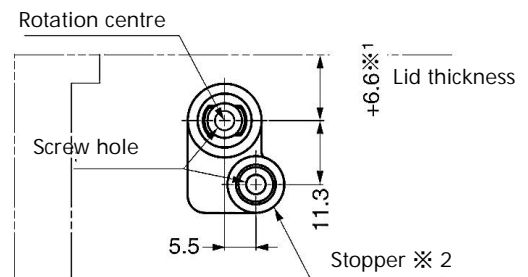

Torque hinges

Art. no.: 150.HG-JHS9-U (perforated and countersunk)

Small damper hinge with self-opening function for top-opening lids.

Operating temperature: 0 ~ 40 ° C

Opening angle (105°)

Opening speed is adjustable with a hex key.

Pressure cap sold separately

Sold in pairs.

Series	Article no.		Torque in Nm/Pair
	Material		
	Black	White	
150. HG-JHS9-U	BL.87	WT.81	0.027~0.043

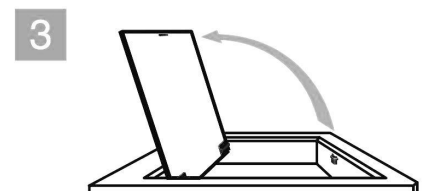
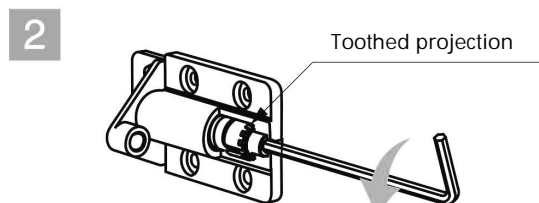
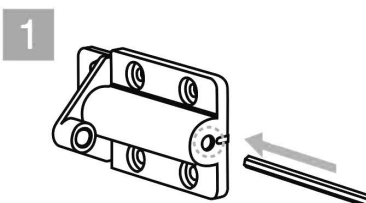
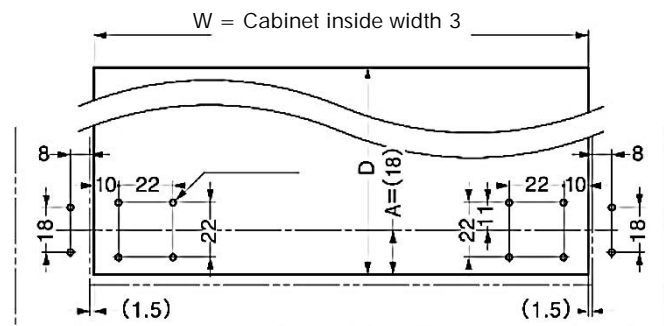
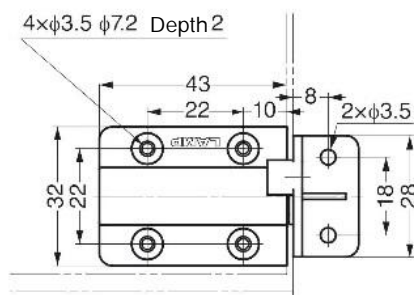
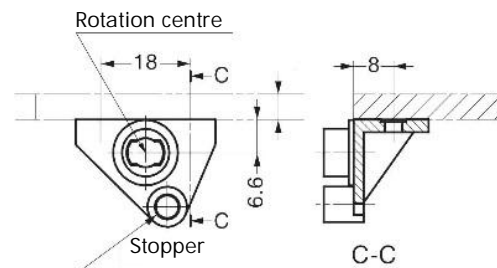
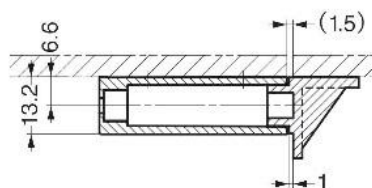
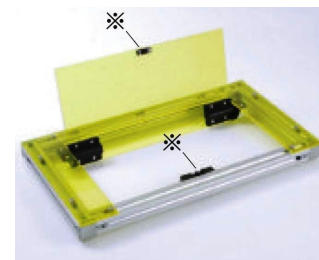
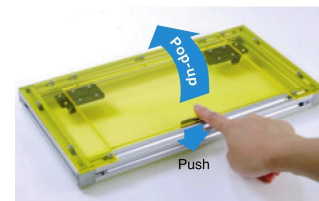

Torque hinges

Art. no.: 150.HG-JHS9 S
Art. no.: 150.HG-JHS9 U



Additional information:
When increasing lid opening speed

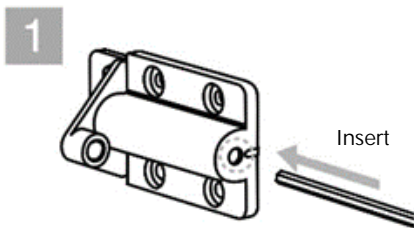
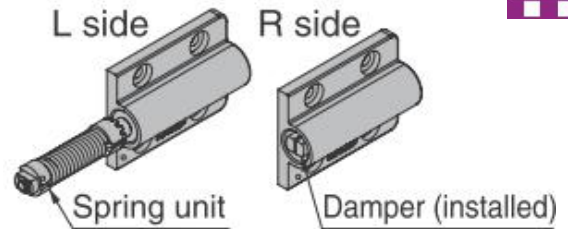

Insert a hex key (size 2,5) into the hole of spring unit (L Seite).

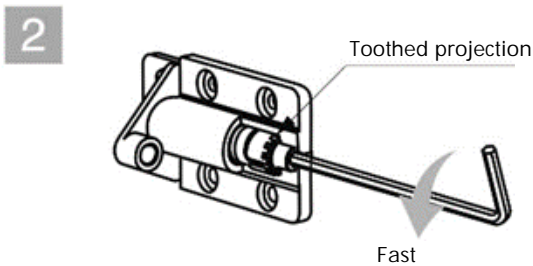

Push in the hex key until toothed projection disengaged, while rotating counterclockwise by 30° and then pull it out.

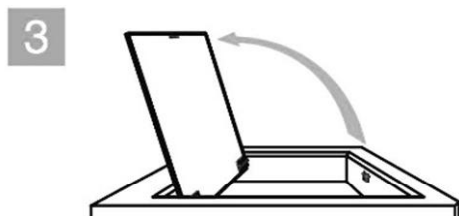

Close the lid and check if the lid can be opened smoothly. Repeat steps 1-3 (maximum 1-2 times) if lid opening speed is still slow.

Make sure to rotate counterclockwise following pushing in the hex key and disengaged the projection. Forced rotation may cause damage.

Torque hinges

Art. no.: 150.HG-CSH63 (perforated)

With constant torque and detent function.

Detent at both 0° and 100°.

Torque not adjustable.

Also available as:

Free running hinge see chapter „hinges“



Type 1

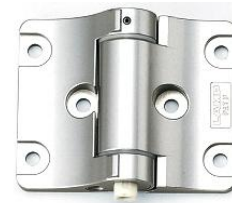

Type 2



Type 3

Article no.			Torque in Nm
Series	Execution	Material Anodized Aluminium	
150.HG-CSH63	1	.71	Without damper
150.HG-CSH63	AM2	.71	1~1.7
150.HG-CSH63	AH2	.71	1.7~2.5
150.HG-CSH63	BM3	.71	1~1.7
150.HG-CSH63	BH3	.71	1.7~2.5

Fig. A (Correct installation)

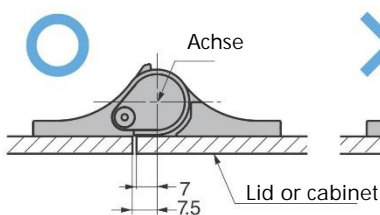
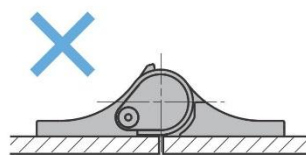
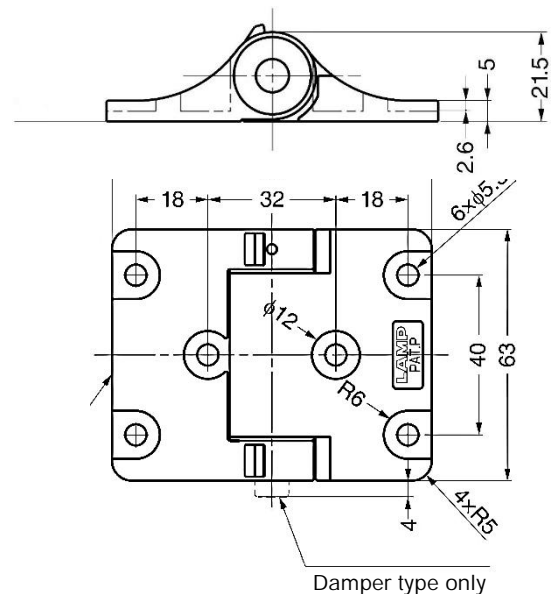

Fig. B (Wrong installation)



As shown in „Fig. A“ shift the axis of hinge and the edge of lid or cabinet.



Type 1
Without damper

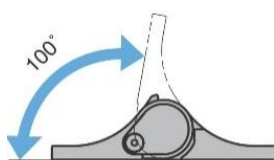

Type 2
With damper

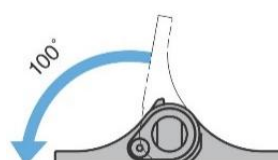

Type 3
With damper

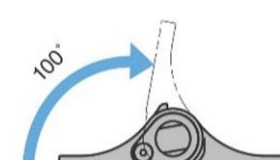

Torque hinges

Art. no.: 150. HG-PA180-9 (perforated)

Lift Assist with adjustable torque.
with plastic cover (PBT light grey)

Easy to lift heavy top-opening lid with spring tension.
Smooth and soft-closing movement at the end, preventing
Lid from slamming shut.

Torque is adjustable by turning the adjustment screw ($\pm 11\%$).

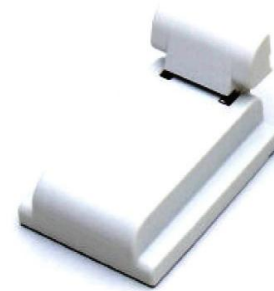

Article no.		Torque in Nm
Series	Material	
150. HG-PA180-9	Stainless steel .30	9



Torque adjustment screw
(Adjustment range $\pm 11\%$)

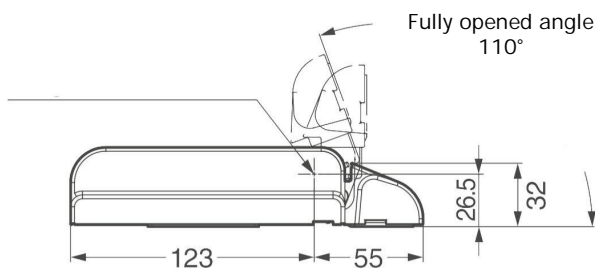
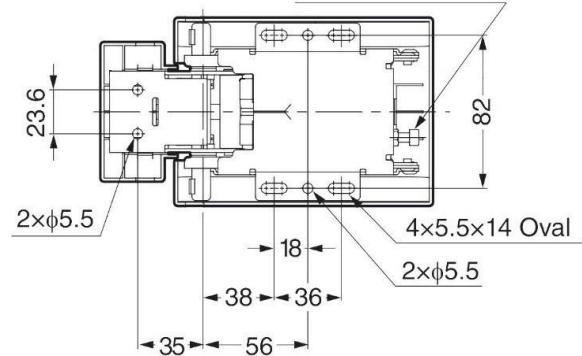
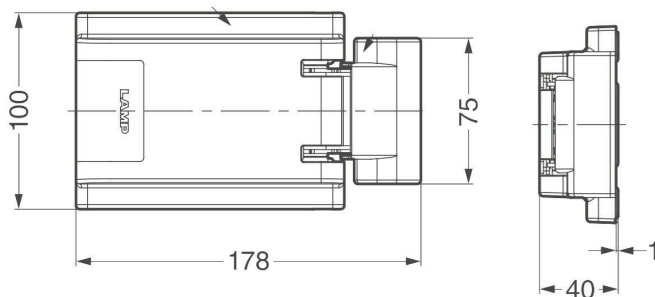

Installation

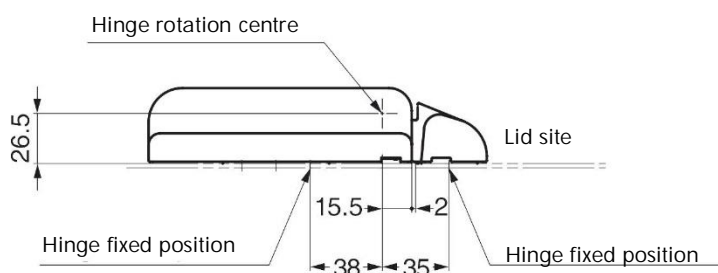

- Free
- Lift assist
- Soft-close

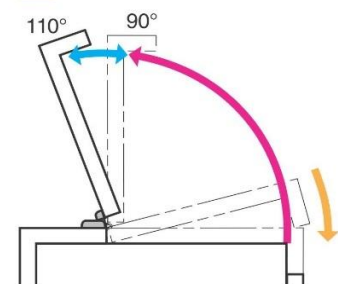

Torque hinges

Art. no.: 150. HG-PA200, HG-PA201 (perforated)



Lift-Assist with adjustable Torque
with plastic cover (PBT light grey)

Easy to lift heavy top-opening lid with spring tension.

Smooth and soft-closing movement at the end,
preventing lid from slamming shut.

Torque is adjustable by turning the adjustment screw ($\pm 5\%$).

Install a stopper (not included) on the cabinet to prevent from exceeding
the operating angle during opening or closing.

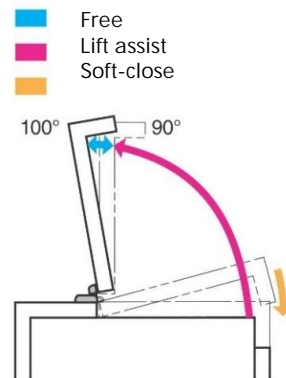
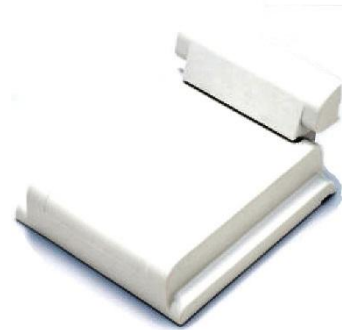

Article no.		Torque in Nm
Series	Material	
	Stainless steel	
150. HG-PA200-15	.30	15
150. HG-PA200-20	.30	20
150. HG-PA200-25	.30	25
150. HG-PA201-15	.30	15
150. HG-PA201-20	.30	20
150. HG-PA201-25	.30	25

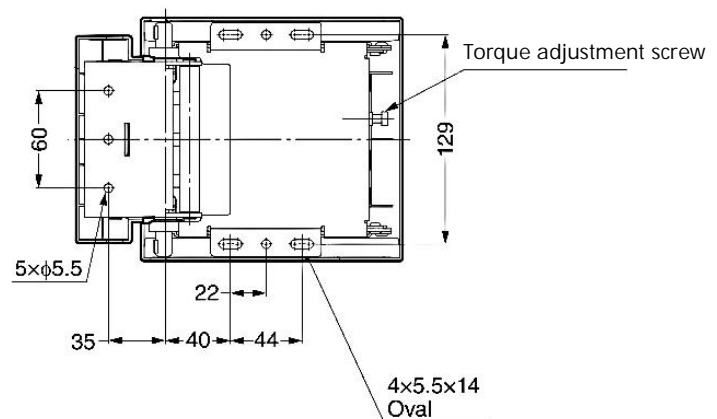
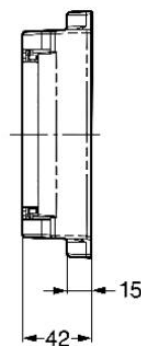
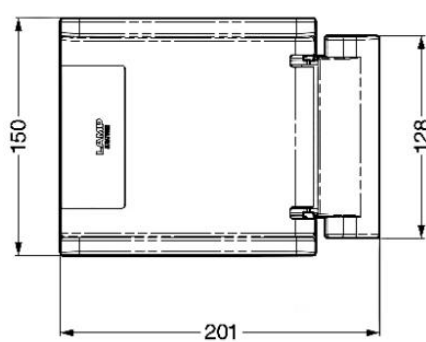

Installation

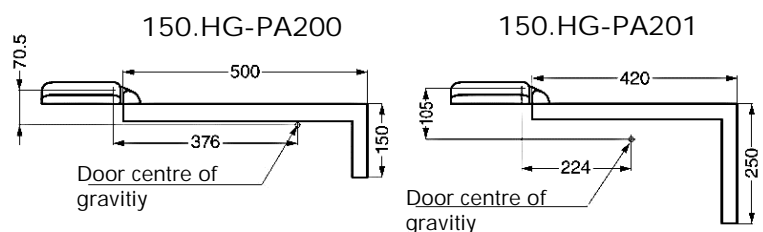
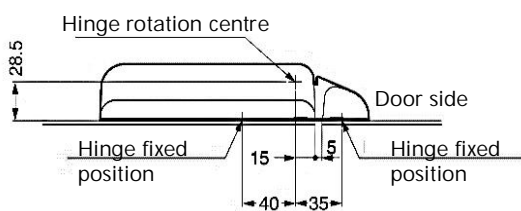

Torque hinges

Art. no.: 150. HG-PA270 (perforated)

Lift-Assist with adjustable torque.
with plastic cover (PBT light grey)

Easy to lift heavy top-closing lid with spring tension.

Smooth and soft-closing movement at the end, preventing
Lid from slamming shut.

Torque is adjustable by turning the adjustment screw ($\pm 5\%$).

Install a stopper (not included) on the cabinet to prevent
from exceeding the operation angle during opening or closing.

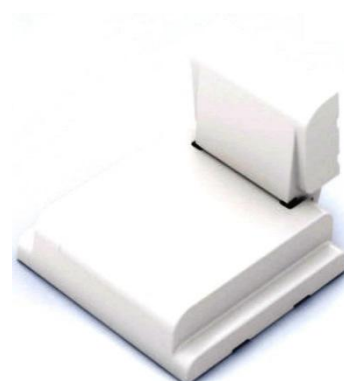

Article no.		Torque in Nm
Series	Material Stainless steel	
150. HG-PA270-35	.30	35
150. HG-PA270-45	.30	45

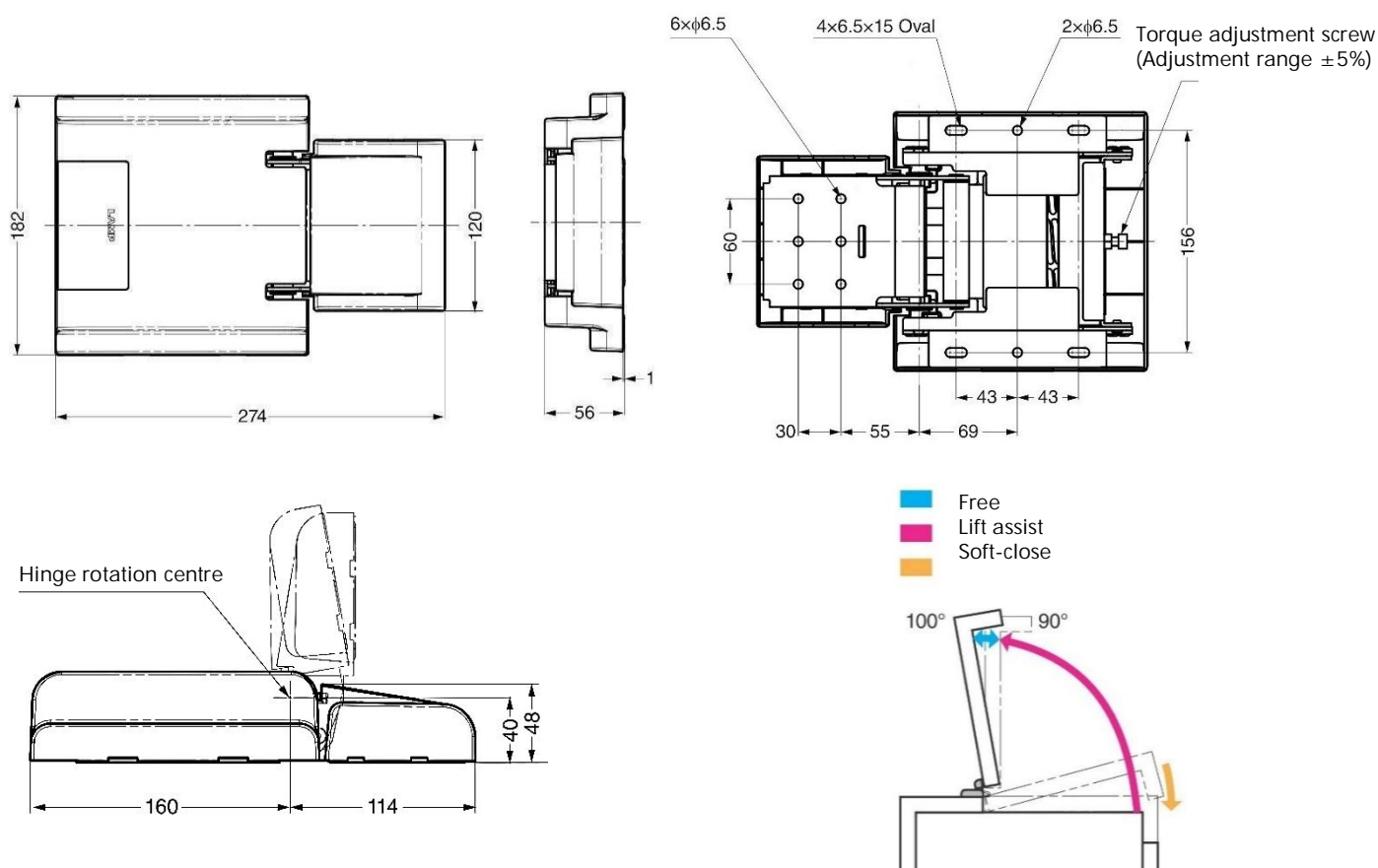

Torque hinges

Art. Nr.: 150. HG-PA210-9 (perforated)

Lift-Assist with adjustable torque and stopper plate with plastic cover (PBT light grey)

Able to limit the 140° opening angle to 55° or 80° with use of the included stopper plate.

Smooth and soft-closing movement at the end, preventing lid from slamming shut.



Torque is adjustable by turning the adjustment screw ($\pm 11\%$).

Article no.		Torque in Nm
Series	Material	
150.HG-PA210-9	Stainless steel .30	9

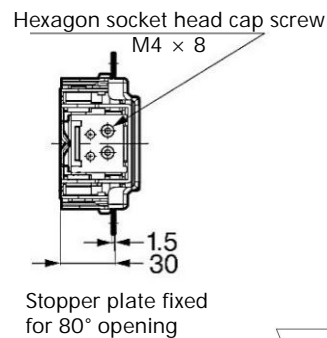
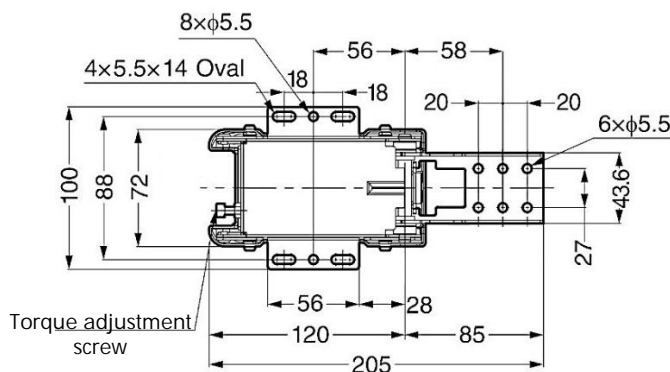

■ Lift assist
■ Soft-close

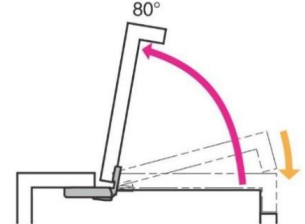

Full opening angle without stopper (140°) When stopper is fixed for 55° opening

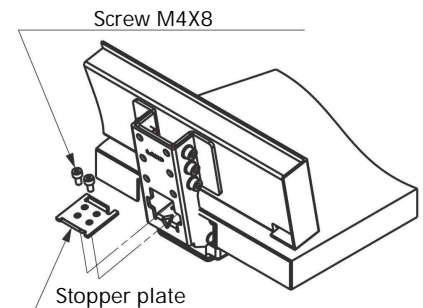
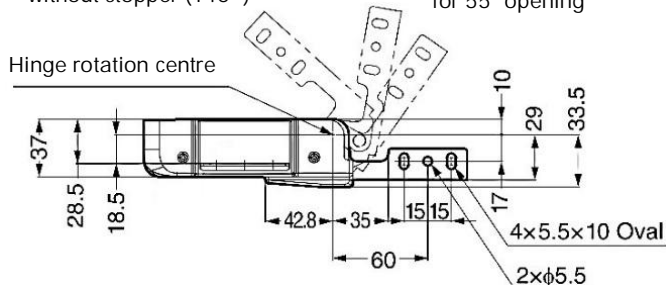

Installation

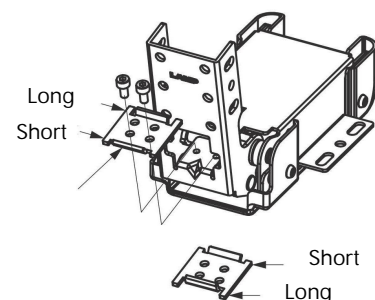
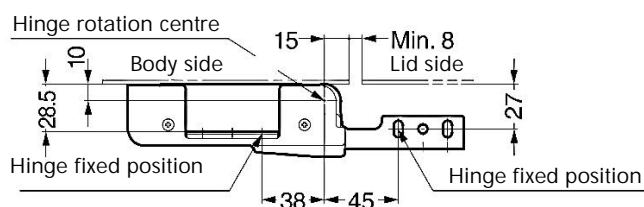

Torque hinges

Art. Nr.: 150. HG-PA230, HG-PA231 (perforated)

Lift-Assist with adjustable torque and stopper plate with plastic cover (PBT light grey)

Easy to lift heavy top-opening lid with spring tension.

Torque is adjustable by turning the adjustment screw ($\pm 5\%$).

Able to limit the 140° opening angle to 55° or 80° with use of the included stopper plate.



Article no.		Torque in Nm
Series	Material	
150. HG-PA230-15	.30	15
150. HG-PA230-20	.30	20
150. HG-PA230-25	.30	25
150. HG-PA231-15	.30	15
150. HG-PA231-20	.30	20
150. HG-PA231-25	.30	25

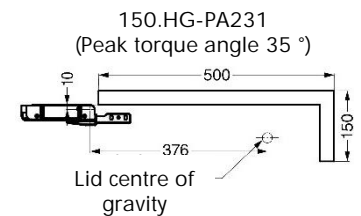
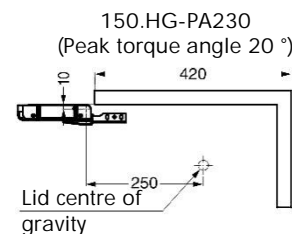

■ Lift assist
■ Soft-close

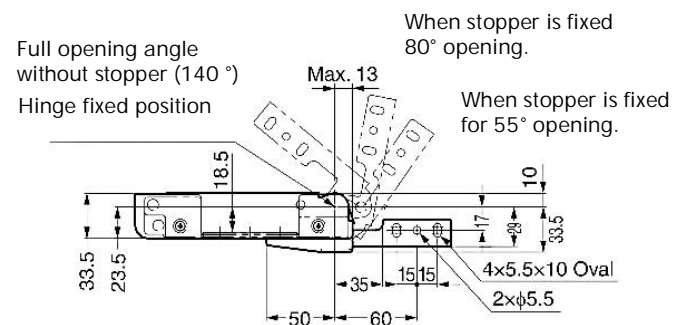
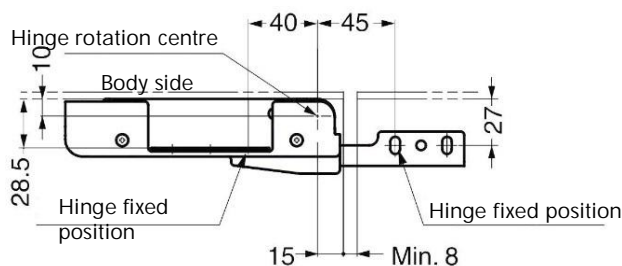
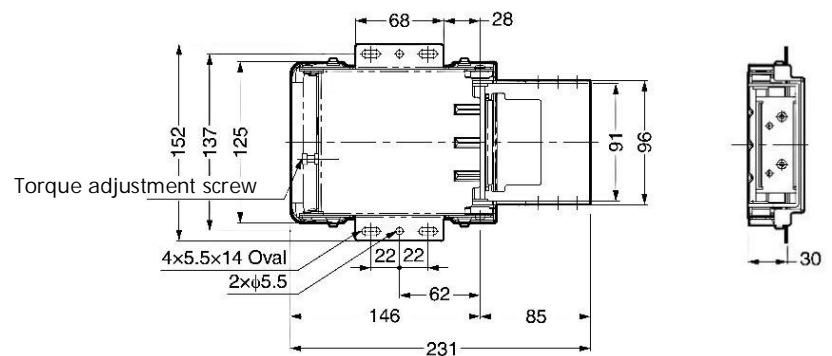
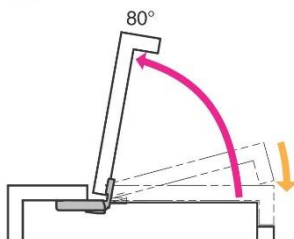

Detent hinges

Art. no.: **6874** (perforated and countersunk)

Locking position every 30° from 0° to 270°.
With 3 different available locking moments.

Also available as:

Free running hinge see chapter „Hinges “

Spring hinge see chapter „Spring hinges “

Torque hinge see chapter „Torque hinges “

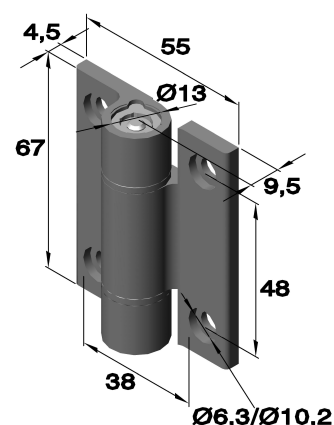

Article no.			Torque in N.m
Series	Execution	Material	
		Black	
		Alu. 6060 T5	
6874	.01	.77	1,8
6874	.02	.77	2,5
6874	.03	.77	3,2
6874	.04	.77	5,0

Art. no.: **6875** (perforated and countersunk)
with stainless steel pin (1.4305)

Locking positions every 90°.
Maximum weight of the door: 1.2 kg for 2 hinges.

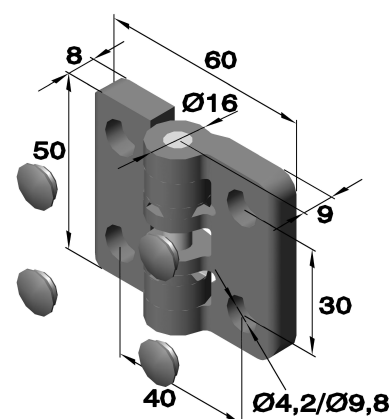

Article no.			Material
Series	Execution	Material	
		Polyacetal	
6875	.01	.80-Ivory	
6875	.02	.80-Black	

Art. no.: **6871** (perforated and countersunk)

All catch positions 30° from 0° to 270°
Drag moment is not adjustable!

Also available as:

Spring hinge see chapter „Spring hinges“

Torque hinge see chapter „Torque hinges “

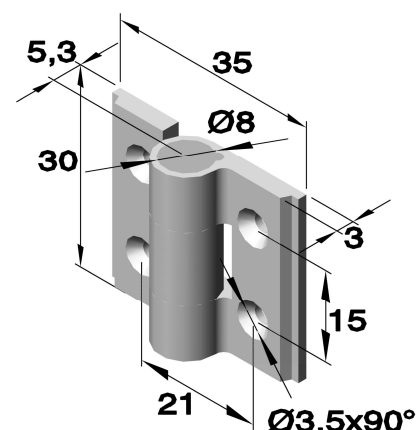

Article no.			
Series	Execution	Material	
		Anodized pale	Anodized black
		Alu 6060 T5	Alu 6060 T5
6871	.06	.71	.77

Detent hinges

Art. no.: 150.HG-MPS2 (perforated)



Detent positions: -10°, 120° und 170°.
Can be used horizontally or vertically.

Additional stopper is recommended at 0° (fully closed) and 170° (fully opened).

For indoor use only.
Not suitable for wet applications.



Article no.		Retaining torque in Nm		
Series	Material		-10°, 170°	120°
	PBT		0.26	0.145
	Black	White		
150.HG-MPS2	-BL.87	-WT.81		

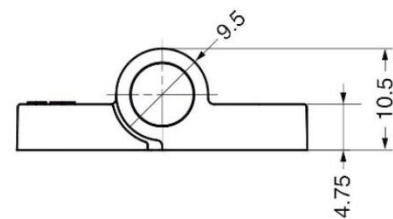
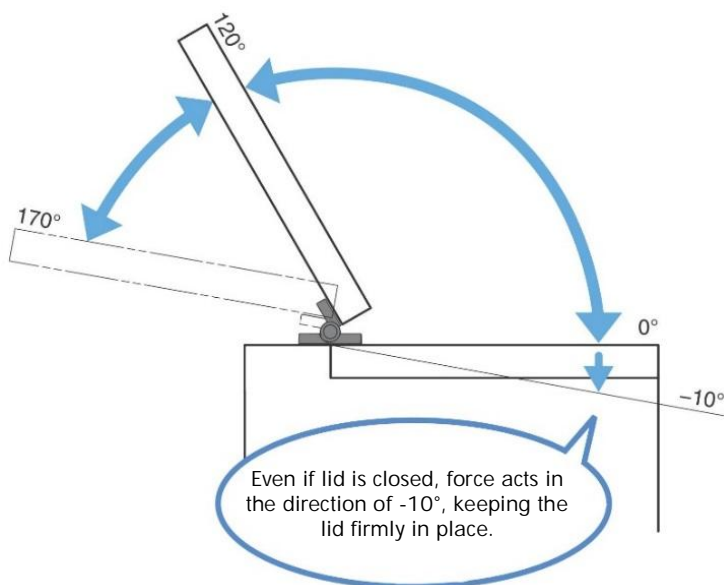
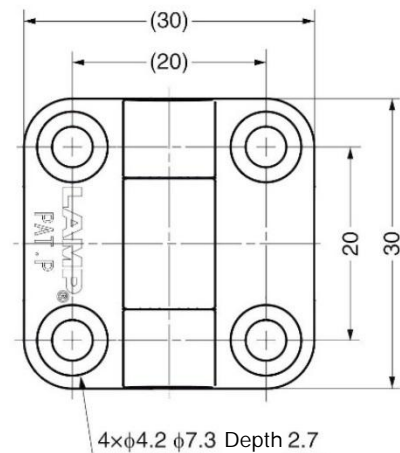
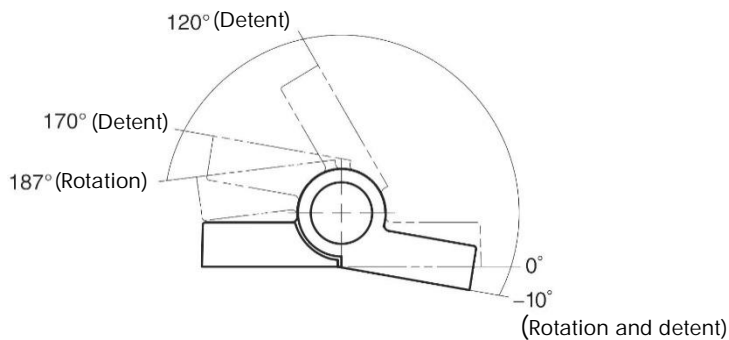

Detent hinges

Art. no.: 150.HG-FH128 (perforated and countersunk)



Detent position: bei 60 ° und 120 °.

Depth and horizontal adjustment can also made after installation.

Fluororesin washer at rotation part ensures smooth operation.



Article no.		Retaining torque in Nm/Pair
Series	Material	
	Zamak	10
	Nickel plated	
150.HG-FH128	.51	

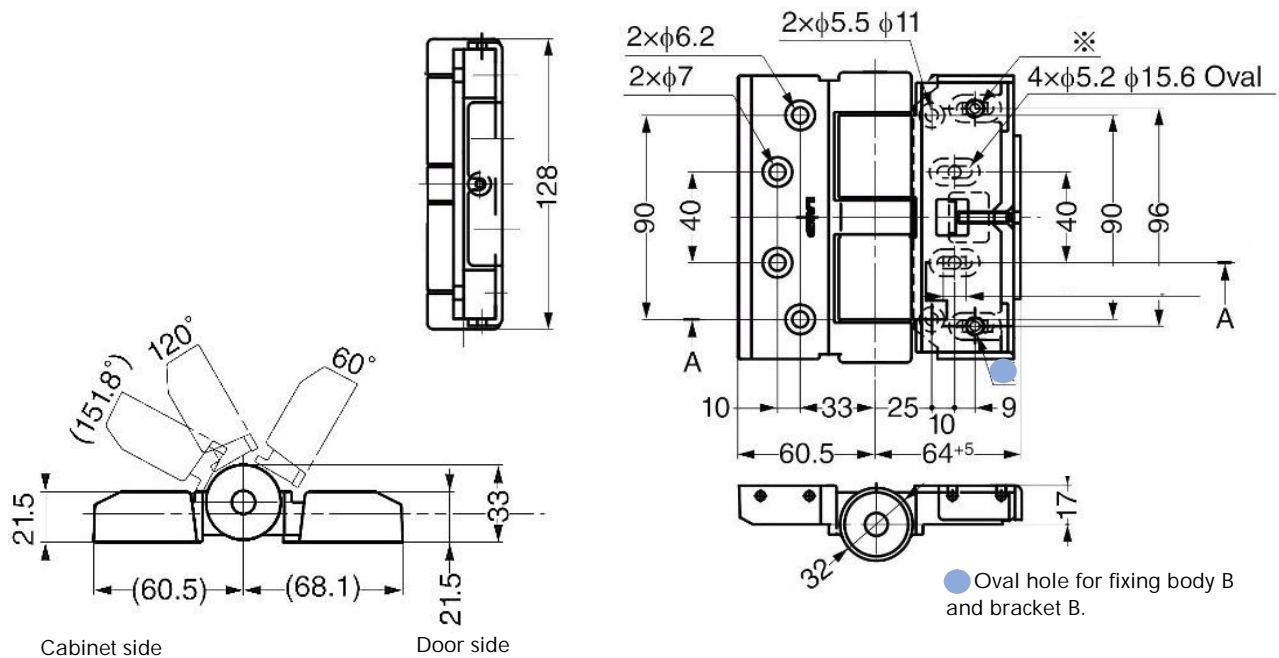

Cut out dimensions

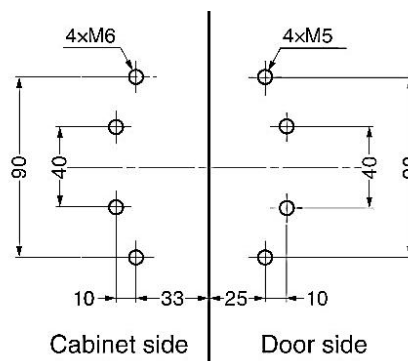

Detent hinges

Art. no.: 150.CH-75 (perforated and countersunk)

Detent positions: 0°, 90° und 180°

Cushion function absorbs impact at full opening and unexpected external force.

Removable hinge pin allows easy installation.

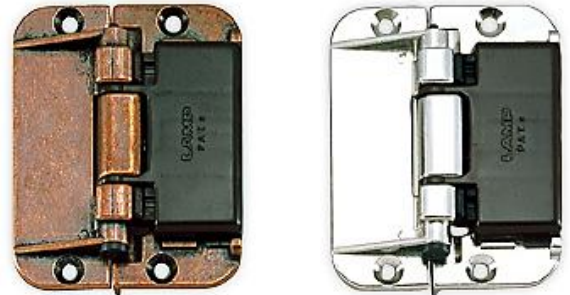

Article no.		
Series	Material	
	Zamak	
	vernickelt	verbronz
150.CH-75	-NI.51	-GB.55

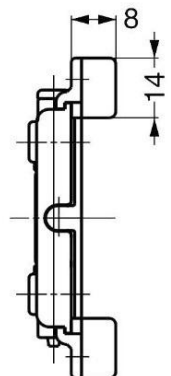
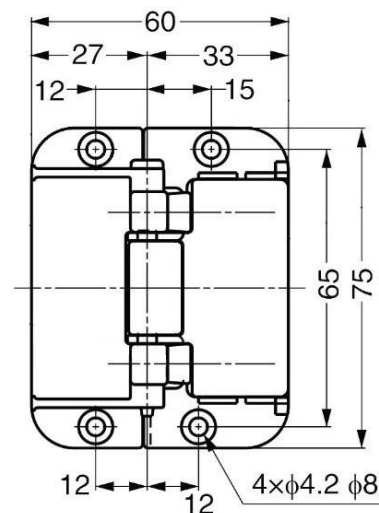
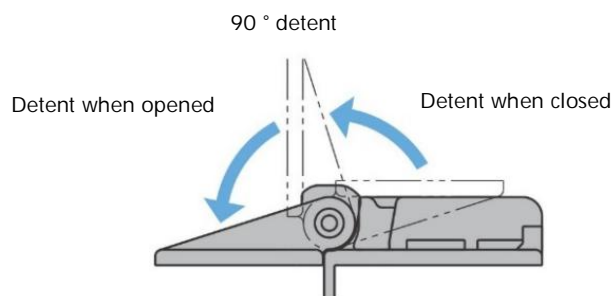
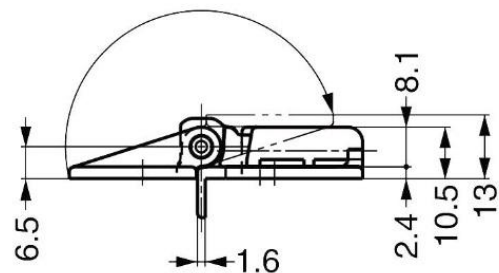

Detent hinges

Art. no.: 150. HG-RCT12-C (perforated and countersunk)



Ratchet mechanism holds at angles in 5° increment from closed to opened position.

The friction (resistance) function works even when release the ratchet mechanism.

When the mounting width of hinge is more than 400mm, the ratchet mechanism may not work simultaneously on the left and right.

Use in pairs.



Article no.		Allowable movement Nm/Pair
Series	Material	
	Nickel plated	40
	Steel	
150.HG-RCT12-C	.01	

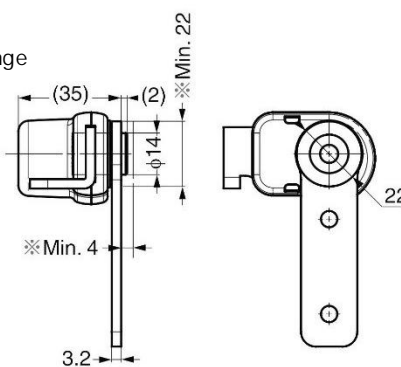
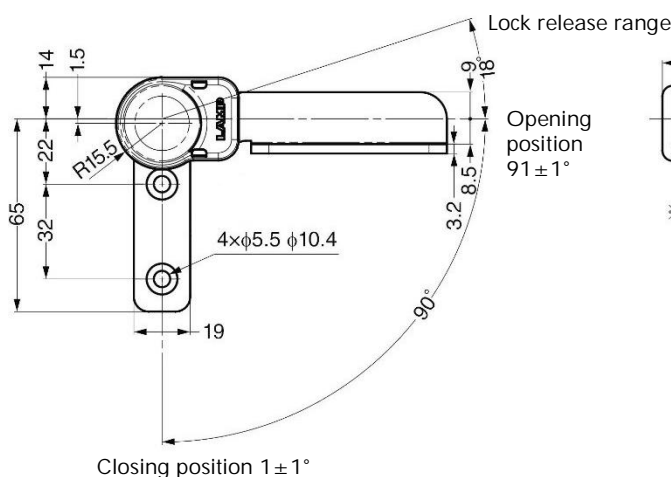
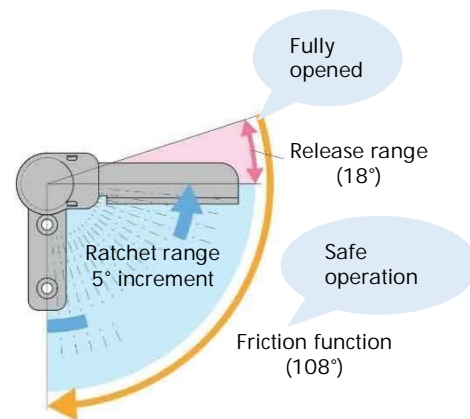
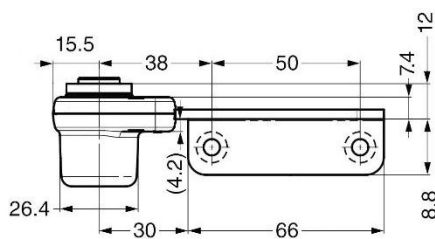
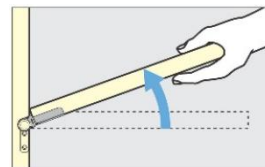

Undercut for the ※ area is needed.
Right- handed type shown.